

Dolski Rejestr Statków

RULES FOR THE CLASSIFICATION AND CONSTRUCTION OF SEA-GOING SHIPS

PART IV STABILITY AND SUBDIVISION

2019
January



GDĄSK

RULES FOR THE CLASSIFICATION AND CONSTRUCTION OF SEA-GOING SHIPS prepared and edited by Polski Rejestr Statków, hereinafter referred to as PRS, consist of the following Parts:

- Part I – Classification Regulations
- Part II – Hull
- Part III – Hull Equipment
- Part IV – Stability and Subdivision
- Part V – Fire Protection
- Part VI – Machinery Installations and Refrigerating Plants
- Part VII – Machinery, Boilers and Pressure Vessels
- Part VIII – Electrical Installations and Control Systems
- Part IX – Materials and Welding.

Part IV – Stability and Subdivision – January 2019 was approved by PRS Executive Board on 20 December 2018 and enters into force on 1 January 2019.

From the entry into force, the requirements of *Part IV – Stability and Subdivision* apply, in full, to new ships.

With respect to existing ships, the requirements of *Part IV – Stability and Subdivision* are applicable within the scope specified in *Part I – Classification Regulations*.

The requirements of *Part IV – Stability and Subdivision* are extended by the following Publications:

- Publication No. 6/P – Stability,
- Publication No. 14/P – Principles of Approval of Computer Programs,
- Publication No. 16/P – Loading Guidance Information,
- Publication No. 32/P – The Requirements for the Stowage and Securing of Cargo on Sea-going Ships,
- Publication No. 66/P – Onboard Computers for Stability Calculations,
- Publication No. 76/P – Stability, Subdivision and Freeboard of Passenger Ships Engaged on Domestic Voyages,
- Publication No. 94/P – Subdivision and Damage Stability of New Oil Tankers, Chemical Tankers and Gas Carriers.

CONTENTS

Page

1 General	5
1.1 Application	5
1.2 General	5
1.3 Definitions	5
1.4 Documentation.....	8
1.5 Scope of Survey.....	9
1.6 General Requirements	10
1.7 Inclining Test.....	17
1.8 Stability Criteria	19
1.9 Departures from and Interpretation of Rules	20
1.10 Passage beyond Specified Navigation Area	20
1.11 Required Bow Height	21
1.12 Ballast water exchange	21
1.13 Freeboard.....	21
2 Basic Requirements and Criteria	22
2.1 Unrestricted Service Ships.....	22
2.2 Restricted Service Ships	25
3 Stability – Detailed Requirements for particular Types of ships	28
3.1 Passenger Ships	28
3.2 Dry Cargo Ships	29
3.3 Container Ships.....	30
3.4 Tankers	31
3.5 Timber Carriers.....	32
3.6 Special Purpose Ships.....	34
3.7 Fishing Vessels.....	34
3.8 Tugs.....	35
3.9 Supply Vessels.....	37
3.10 Ships Intended for Carriage of Dangerous Bulk Cargoes	38
3.11 High-speed craft	39
3.12 Chemical Tankers	39
3.13 Gas Tankers	39
3.14 Ships intended to operate in polar waters	40
4 Stability – requirements for Technical Floating Units	41
4.1 Floating Cranes.....	41
4.2 Dredging Fleet	49
4.3 Pontoons	53
5 Subdivision	55
5.1 Application	55
5.2 General Requirements	55
5.3 Basic Requirements for Various Ship Types	57
5.4 Regional Requirements for Damage Stability of Ro-ro Passenger Ships	62
5.5 Ships intended to operate in polar waters	62
Supplement – Retroactive Requirements	63
Annex 1	64
Annex 2	66

Annex 3	68
Annex 4	69
Annex 5	71
Annex 6	74
Annex 7	75

1 GENERAL

1.1 Application

1.1.1 *Part IV – Stability and Subdivision* applies to buoyancy of sea-going ships closed by deck, specified in para. 1.1.1 of *Part I – Classification Regulations*.

1.2 General

1.2.1 All ships to be assigned PRS class shall fulfil the applicable requirements of *Part IV*. Compliance with the requirements, specified in Chapters 3, 4 and 5, is documented by an appropriate additional mark, affixed to the symbol of class.

The stability of unrestricted ships shall fulfil the requirements based on the stability criteria in accordance with the *IMO International Code on Intact Stability (Resolution MSC.267(85))* adopted on 4 December 2008 and corrigendum introduced by IMO document MSC 85/26/Add.1/Corr.3/Rev.1 adopted on 09 October 2018.

1.2.2 Restricted service ships which are not covered by IMO IS Code shall fulfil the requirements specified in sub-chapter 2.2.

1.2.3 Technical floating units shall fulfil the requirements specified in Chapter 4.

1.2.4 The requirements concerning the ship subdivision are specified in Chapter 5.

1.2.5 PRS may consider the requirements for stability and subdivision as fulfilled if:

- .1 the stability and subdivision have been considered by the Flag State Administration as complying with the requirements of that Administration and the level of these requirements is not lower than that set forth in *IMO IS Code (Resolution A.267(85))*, the *International Convention for the Safety of Life at Sea, 1974* (hereinafter referred to as *SOLAS Convention or SOLAS*) and the *International Convention for the Prevention of Pollution from Ships, 1973* (hereinafter referred to as *MARPOL 73/78*);
- .2 the Owner has submitted, to PRS, a copy of the documentation approved by this Administration;
- .3 the scope of the approved documentation meets the requirements specified in Part IV or is considered by PRS as sufficient.

1.2.6 With respect to existing ships to be assigned PRS class, the scope of the requirements is specified by PRS in each particular case, having regard to the principles given in Chapter 4 of *Part I – Classification Regulations*. With respect to intact stability of the ship, the requirements based on *IMO IS Code (Resolution MSC.267(85))* apply.

1.2.7 IMO Conventions, Codes and Resolutions, referred to in *Part IV*, are the latest versions of these documents, as amended.

1.2.8 Delivery documentation prepared on the basis of documents, specified in 1.2.7, shall be marked with the IMO ship identification number.

1.3 Definitions

The definitions relating to the general terminology of the *Rules for the Classification and Construction of Sea-going Ships* (hereinafter referred to as the *Rules*) are given in *Part I – Classification Regulations*. In the present chapter, the definitions, symbols and abbreviations, specific for *Part IV*, have been provided.

After perpendicular – the perpendicular at the intersection of the summer load waterline with the axis of the rudder stock.

Base plane – horizontal plane which crosses amidships the top of a flat keel or the intersection of the inner surface of the plating with the bar keel.

Breadth of ship B – the maximum breadth of the ship measured amidships to the moulded line of the frame in a ship with a metal shell and to the outer surface of the hull in a ship with a shell of another material.

Bulkhead deck – the uppermost deck up to which transverse watertight bulkheads are carried.

Capsizing moment M_{kr} – conventional design moment, applied dynamically taking account of the ship rolling, which heels the ship to an angle equal to the angle of capsizing or the angle of flooding, or the dynamic margin angle of heel (where determined), whichever is lesser.

Cargo ship – any ship which is not a passenger ship.

Compartment – part of the ship inner space bounded by the ship bottom, sides, bulkhead deck and two adjacent transverse watertight bulkheads or the bulkhead and shell plating of the peak.

Corrected metacentric height – metacentric height decreased by correction for free surfaces.

Correction for free surfaces – correction taking into account the decrease of the ship stability due to the effect of liquids free surface.

Cross curves – arms of form stability.

Damage waterline – waterline of the damaged ship with one compartment or a group of adjacent compartments flooded.

Dangerous bulk cargo – grain* or other solid bulk cargo** which, under sea transport conditions, is liable to shift. Solid bulk cargo is classified as hazardous cargo in accordance with the *Code of Safe Practice for Solid Bulk Cargoes (BC Code)* in force.

Dead weight – difference, in tonnes, between the displacement of a ship in water of specific gravity equal 1.025 t/m³ at the summer load waterline and the lightweight of the ship.

Deckhouse – a decked structure on the freeboard deck (or on the superstructure deck) with the sides (one or both) being inboard of the ship sides more than 0.04 B .

Deepest subdivision load line – the waterline which corresponds to the greatest draught permitted by the applicable subdivision requirements.

Design length of ship L_0 – a length measured on a summer load waterline from the fore side of the stem to the centre of the rudder stock. The assumed value of L_0 shall not be less than 96% and need not be greater than 97% of the extreme length on the summer load waterline. In ships with unusual stern and bow arrangement, the length L_0 is subject to PRS consideration in each particular case.

Displacement of ship D – mass of water, in tonnes, of the volume equal to the volume of the submerged part of the ship hull.

Draught of ship T – vertical distance measured amidships from the base plane to the summer load waterline.

Equalization of ship – activities aimed to eliminate or reduce the heel and trim after flooding a compartment/compartments as a result of damage.

Forward perpendicular – perpendicular at the intersection of the summer load waterline with the fore side of the stem. For ships with unconventional stem curvature, the position of the forward perpendicular is subject to special consideration by PRS.

Freeboard deck – deck to which the freeboard is measured and calculated in accordance with the *International Convention on Load Lines, 1966* – generally it is the uppermost complete deck exposed to weather and sea, which has permanent means of closing all openings in the weather part thereof, and below which all openings in the sides of the ship are fitted with permanent means of weathertight closing.

* See *International Code for the Safe Carriage of Grain in Bulk*.

** See *International Maritime Solid Bulk Cargoes (IMSBC Code)*.

Heeling moment M_w – conventional design moment caused by dynamic action of the wind.

Homogeneous cargo – cargo having constant stowage factor.

Inclining test – test performed to determine the lightweight of the ship and the position of its centre.

Intact ship flooding angle – the smallest angle of heel at which the ship interior spaces are flooded by water through openings in the hull, superstructures or deckhouses, considered to be open.

Length of the ship L – 96% of the total length on a waterline at 85% of the moulded depth, measured from the base plane, or the length from the fore side of the stem to the axis of the rudder stock on that waterline, if that be greater. In ships designed with a rake of keel, the waterline on which this length is measured shall be parallel to the design waterline. In ships with unusual stern and bow arrangement, length L is subject to special consideration by PRS.*

Light ship – a ship ready for operation, but without cargo, stores, ballast water, passengers, crew and their effects. The weight of mediums on board for the fixed fire-fighting systems (e.g. freshwater, CO₂, dry chemical powder, foam concentrate, etc.) shall be included in the lightweight and lightship condition.

Lightweight – mass of a ship, in tonnes, without cargo, fuel, lubricating oil, ballast water, fresh water and feedwater in tanks, stores, as well as passengers and crew and their effects.

Margin line – line drawn at least 76 mm below the upper surface of the bulkhead deck at side.

Midship section – hull cross-section at the middle of the distance between the fore perpendicular and aft perpendicular.

Minimum draught of ship T_{\min} – the minimum average draught of the ship without cargo, with 10% stores, including such water ballast as may be necessary.

Moulded depth of ship H – vertical distance measured amidships from the base plane to the top of the uppermost continuous deck beam at side. In ships having a rounded gunwale, the moulded depth shall be measured to the point of intersection of the moulded lines of the deck and side.

If the uppermost continuous deck is stepped and the raised part of the deck extends over the point at which the moulded depth is to be determined, the moulded depth shall be measured to a line of reference extending from the lower part of the deck along a line parallel with the raised part.

Passage outside the assigned area of navigation – the ship navigation outside the assigned area of navigation after fulfilling the specified requirements and based on the permit granted in each particular case.

Permeability of space – ratio of the volume which can be occupied by water to the whole volume of the space.

Pontoon – non-self-propelled ship, unmanned, intended for the carriage of deck cargo only, having no hatchways on the deck, except access openings such as manholes, closed with gasketed covers.

Ro-ro passenger ship – a passenger ship with ro-ro spaces or special category spaces, as defined in SOLAS II-1/2.

Stability booklet – a document containing reliable information enabling the master, by rapid and simple processes, to obtain accurate guidance as to the stability of the ship in any loading condition.

Stores – fuel oil, fresh water, provision, lubricating oil, consumables.

Subdivision – capability of a ship, after damage and flooding of a compartment or adjacent compartments, to maintain buoyancy and stability in accordance with the requirements specified in the present part of the *Rules*.

* According to the *Load Line Convention* in force.

Subdivision breadth of ship B_s – the greatest breadth of ship measured at the deepest subdivision load line between the outer edges of frames in a ship with metal shell plating or between the outer surface of the hull in a ship with the shell plating of any other material.

Subdivision index A (attained) – attained, by way of calculations, probability of the ship survival after the flooding of compartment/compartments as a result of damage.

Subdivision index R (required) – required probability of the ship survival after the flooding of compartment/compartments as a result of damage.

Subdivision length of ship L_s – the greatest projected moulded length of that part of the ship at or below deck (or decks) limiting the vertical extent of flooding with the ship at the deepest subdivision load line (*SOLAS II-1/2*)*.

Subdivision load line – waterline used in determining the subdivision of the ship.

Superstructure – decked structure on the freeboard deck, extending from side to side of the ship or with one side or both sides being inboard of the ship sides not more than $0.04B$. A raised quarter deck is considered as a superstructure.

System of roll stabilization – special active or passive equipment for reducing the ship rolling amplitude.

Type A ship, Type B ship – see the *International Convention on Load Lines, 1966*, regulation 27.

Upper deck – the uppermost continuous deck extending over the full length of ship.

1.4 Documentation

1.4.1 Depending on the ship construction stage, the documentation, as specified in 1.4.1.1 and 1.4.1.2, shall be submitted to the PRS Head Office for consideration.

1.4.1.1 Prior to the commencement of the ship construction or alteration, the following shall be submitted for information:

- .1 General arrangement plan;
- .2 Arrangement plan of outer doors, companionways and sidescuttles (see also 1.6.5);
- .3 Body lines or the body lines table;
- .4 Hydrostatic curves, cross curves of stability – print-outs of calculation results where computer programs, not approved by PRS, are used;
- .5 Calculations of: heeling levers due to the effect of wind (without icing and with icing), including the windage area diagram, flooding angles, icing (the mass of ice and the position of the centre of mass), liquid free surface effect on the ship stability;
- .6 Calculations and diagrams of the permissible value of the vertical coordinate of the ship centre of mass KG_{max} (or GM_{min}), depending on the ship draught or displacement (see 1.6.11);
- .7 Plan of cargo compartments, tanks, including sounding tables and the plan of cargo decks with particulars of its loading area (cargo sections) as well as coordinates of its geometrical centres (see 1.6.4);
- .8 Plan of permanent ballast, where provided;

and for acceptance (preliminary approval):

- .9 *Preliminary Stability Booklet* (see 1.4.4).

1.4.1.2 Upon completion of the ship construction or alteration, the following shall be submitted to PRS for approval:

- .1 *Stability Booklet* prepared on the basis of the inclining test data (see 1.7);
- .2 Loading plan of grain or other solid bulk cargoes (if provision has been made for the carriage of such cargoes);

* Applies to cargo ships subject to the requirements of *SOLAS Convention*, Chapter II-1, Part B-1.

and for information:

- .3 Inclining test report, accepted by PRS Surveyor;
- .4 Updated documentation, referred to in 1.4.1.1.1 to 1.4.1.1.8 (if changes have been introduced thereto).

1.4.2 For ships, to which the requirements of the present part of the *Rules* concerning subdivision apply, the documentation, specified in 1.4.2.1 and 1.4.2.2, shall be additionally submitted to PRS Head Office for consideration.

1.4.2.1 Prior to the commencement of the ship construction or alteration, the following shall be submitted to PRS for information:

- .1 for both passenger and cargo ships analyzed in probabilistic way:
calculations and drawings related to determination of the subdivision index R (required) and the subdivision index A (attained), as appropriate;
- .2 for ships analyzed in deterministic way:
calculations and drawings necessary for definition of both intact and damage conditions as well as extent of damage;
- .3 calculations and diagrams of the minimum metacentric height GM_{min} and/or permissible value of the vertical coordinate of the intact ship centre of mass KG_{max} , which assures compliance with stability criteria after damage. For passenger ships, the diagrams and calculations shall be made taking into account different trims and operational limits, where applicable (see 1.6.11);

and for acceptance (preliminary approval):

- .4 *Preliminary Damage Control Plan* (see 5.2.4);
- .5 *Preliminary Stability and Subdivision Booklet* (see 1.4.4).

1.4.2.2 Upon completion of the ship construction or alteration, the following shall be submitted to PRS for approval:

- .1 *Stability and Subdivision Booklet*;
- .2 *Damage Control Plan*;

and for information:

- .3 Updated documentation, referred to in 1.4.2.1.1 to 1.4.2.1.3 (if any changes have been made thereto).

Note: The damage stability calculations need not be repeated if the inclining test result satisfies the conditions given in 1.7.2.

1.4.3 Where provision has been made on board for anti-rolling devices or other arrangements having effect on the ship stability (e.g. anti-heeling system in port during loading/discharging operations), the scope of additional documentation and calculations shall be agreed with PRS.

1.4.4 For ships, to whom the requirements of the present part of the *Rules* concerning subdivision apply, *Stability and Subdivision Booklet* complying with the requirements of 1.6.11 and 5.2.4 shall be prepared. For practical reason two separate documents are allowed.

1.4.5 Depending on the ship type, the scope of the required documentation may be extended or limited – in such cases, the detailed requirements are given in chapters referring to particular types of ships.

1.5 Scope of Survey

1.5.1 In respect of stability, PRS survey covers:

1.5.1.1 Prior to the commencement of ship construction:

- .1 consideration of the ship stability documentation and verification of calculations;
- .2 acceptance of *Preliminary Stability Booklet*.

1.5.1.2 During and upon the completion of ship construction:

- .1 acceptance of the hull measurement results (the main dimensions, keel position) and the survey of draught marks location;
- .2 supervision of the inclining test and the acceptance of inclining test report;

- .3 consideration and approval of *Stability Booklet*;
- .4 approval of calculation programs for checking the ship stability during service;
- .5 verifying the operation of the instruments for checking the ship stability while in service;
- .6 checking compliance with the hull watertight integrity requirements;
- .7 for ships carrying dangerous cargoes in bulk: consideration and approval of loading plan – at the Owner’s request.

1.5.1.3 Within the scope of periodical and occasional surveys of the ship:

- .1 checking the validity of *Stability Booklet* and loading plans considering the possible changes of the ship lightweight;
- .2 verifying the operation of instruments for checking the ship stability prior to her departure;
- .3 for passenger ships – lightweight survey to verify the light ship parameters (the ship mass and its longitudinal centre), performed to confirm the validity of *Stability and Subdivision Booklet*, to be available on board the ship (see 1.7.4);
- .4 checking compliance with the hull watertight integrity requirements;
- .5 for fishing vessels – the inclining test survey and the inclining test to verify the light ship parameters (the ship mass and its centre of mass), performed to confirm the validity of *Stability Booklet* (see 1.7.1.5).

1.5.2 In respect of subdivision, PRS survey covers:

1.5.2.1 Prior to the commencement of ship construction:

- .1 consideration of documentation, verification of calculations and acceptance of the ship subdivision;
- .2 acceptance of the diagram of minimal values of metacentric height or permissible values of vertical coordinate of the ship centre of mass while in service (see 1.6.11);
- .3 consideration of preliminary damage control plan;
- .4 consideration and approval of the ship anti-heeling system, where provided.

1.5.2.2 During and upon completion of the ship construction:

- .1 examination of structural means and devices connected with ensuring the watertight integrity of compartments and the ship stability after flooding a compartment/compartments;
- .2 approval of *Stability and Subdivision Booklet*;
- .3 approval of *Damage Control Plan* and associated *Damage Control Manual*;
- .4 checking the correctness of the assignment and marking of subdivision load lines taking account of the requirements for the freeboard assignment.

1.6 General Requirements

1.6.1 General Assumptions and Principles

1.6.1.1 Compliance with the stability criteria does not provide immunity against capsizing and does not absolve the master from his responsibility for the safety of the ship. An additional requirement to ensure the safety of the ship is her proper operation, having regard to the prevailing circumstances.

Note: The term “stability”, used in the present Part of the *Rules*, means intact stability.

1.6.1.2 It is assumed that the master will operate the ship with prudence and good seamanship, with due regard paid to the season of the year, weather forecasts and the navigational zone and will take appropriate action as to speed and course warranted by the prevailing circumstances.

1.6.1.3 It is assumed that the cargo is properly stowed and secured so as to minimize the possibility of longitudinal and transverse shifting, while at sea, under the effect of acceleration caused by rolling and pitching.

1.6.1.4 It is assumed that the ship is so loaded and ballasted (where necessary) that the stability criteria, specific to a particular ship, are fulfilled at all times during a voyage.

1.6.1.5 The number of partially filled tanks shall be kept to a minimum due to their adverse effect on the ship stability.

1.6.1.6 The stability criteria, specified in Chapters 2 and 3, provide the required minimum values of metacentric height. The maximum values have not been determined. It is advisable that excessive values of metacentric height should be avoided since they may lead to acceleration forces – prejudicial to the ship, her equipment, the crew and carried cargo.

1.6.2 Calculation Methods

1.6.2.1 It is recommended that calculations should be made using programs approved by PRS in accordance with *Publication No. 14/P – Principles of Approval of Computer Programs*.

1.6.3 Calculation of Hydrostatic Curves and Cross Curves of Stability

1.6.3.1 Hydrostatic and stability curves shall be calculated on a design trim basis. However, where the operating trim or the form and arrangement of the ship are such that change in trim has an appreciable effect on righting levers, such change in trim shall be taken into account.

1.6.3.2 When calculating cross curves of stability, account may be taken of those tiers of the enclosed superstructures which fulfil the requirements of 7.1.6 of *Part III – Hull Equipment*. Superstructure shall not be regarded as enclosed unless access is provided for the crew to reach machinery or other working spaces inside those superstructures by alternative means which are available at all times when bulkhead openings are closed (see Annex 1).

1.6.3.3 Superstructures, in which no entrance is provided from an exposed deck above (ensuring the crew access to working spaces inside the superstructures and to the machinery space when the bulkheads openings are closed), may be taken into account in stability cross curves calculations in full height if the upper edges of door sills in superstructures at the ship maximum draught immerse at the angle of heel equal to or greater than the required angle of static stability range. If the upper edges of door sills in superstructures immerse at an angle less than the required angle of static stability range, the design height of superstructures shall be assumed to be half their actual height.

1.6.3.4 When calculating cross curves of stability, account may be taken of full height of deckhouses situated on the freeboard deck, provided they fulfil the requirements for enclosed superstructures, specified in 1.6.3.2. Where, in deckhouses, there is no exit to the deck above, such deckhouses shall not be taken into account when calculating the cross curves of stability; however, any deck openings inside such deckhouses may be considered as closed even where no means of closure are provided.

1.6.3.5 Deckhouses, the doors of which do not fulfil the requirements specified in sub-chapter 7.3 of *Part III – Hull Equipment*, shall not be taken into account when calculating the cross curves of stability; however, any deck openings inside the deckhouses shall be considered as closed if their coamings and means of closure fulfil the requirements specified in the relevant paragraphs of *Part II – Hull* and *Part III – Hull Equipment*.

1.6.3.6 When calculating cross curves of stability, account may be taken of the volumes of hatches, situated on the upper deck and fitted with closing devices complying with the requirements of sub-chapter 7.10 of *Part III – Hull Equipment*.

1.6.3.7 The drawing or table of cross curves of stability shall contain a scheme of superstructures and deckhouses taken into account in calculations, indicating the openings considered to be open, as well as a scheme of the part of the upper deck with the wood sheathing taken into account. The location of the point to which cross curves of stability are related shall be indicated.

1.6.3.8 Hydrostatic particulars of the ship shall be calculated for draughts measured in a range covering the light ship and maximum draughts.

1.6.3.9 Hydrostatic particulars shall include:

- extreme displacement in salt water (at stated density),
- immersion (displacement per unit interval of draught),
- moment to change trim one unit,
- transverse metacentric height above the baseline,
- vertical centre of buoyancy (measured from the baseline),
- longitudinal centre of buoyancy,
- longitudinal centre of floatation.

1.6.4 Plans of Cargo Compartments, Tanks and Decks

1.6.4.1 The plan of cargo compartments shall incorporate data, for each cargo space, containing approved permissible loading of cargo spaces, capacities (including the capacities of partly filled cargo holds intended for the carriage of bulk cargoes), the centre of volume coordinates and data enabling to determine the centre of mass coordinates of the loaded cargo.

1.6.4.2 The plan of tanks shall incorporate all tanks other than cargo tanks, tables of volumes and the centre of volume coordinates, as well as data necessary to determine the free surface effect on stability. The plan of tanks shall be supplemented with valid sounding tables.

1.6.4.3 The plan of decks shall contain all data necessary to determine the permissible masses of deck cargoes and cargoes on hatch covers, as well as coordinates of the centres of mass.

1.6.4.4 For ships, specified in 3.2.1, capacity plan shall additionally be prepared; the plan shall show the load line marks, including:

- position of the deck line relative to the ship depth,
- draught to the summer load waterline,
- draught to the summer timber load waterline (if appropriate),
- drawing of the compartments designed for cargo with their geometric data.

This plan shall also show the relationships between mean draught, extreme displacement, immersion (displacement per unit interval of draught) and deadweight. The positions of the draught marks shall be defined in relation to the forward and after perpendiculars.

1.6.5 Arrangement Plan of Doors, Companionways and Sidescuttles

1.6.5.1 The arrangement plan of doors and companionways shall include all doors and companionways leading to open decks, as well as all doors and hatches in the shell plating, with reference made to their drawings. The plan shall also include all sidescuttles located below the continuous upper deck, as well as sidescuttles in the superstructures and deckhouses taken into account in calculations of cross curves of stability.

1.6.5.2 Openings assumed to be open, for which angle of flooding has been determined, shall be indicated on the plan.

1.6.6 Windage Area Calculations

1.6.6.1 The windage area F_w and its static moment shall be calculated for the ship draught T_{\min} .

The windage area for other draughts may be calculated by linear interpolation taking the second point of the draught corresponding to the summer load waterline.

1.6.6.2 The position of the centre of the windage area shall be determined by a common method used for determining the coordinates of plane figure geometric centre.

1.6.6.3 The windage area includes the projections, on the ship centre plane, of all continuous walls and surfaces of the hull, superstructures and deckhouses, masts, ventilators, boats, deck machinery, all tents which may be put up in stormy weather, as well as the projections of lateral surfaces of cargoes to be carried on deck.

It is recommended that the windage area of discontinuous surfaces of rails and rigging (except masts) of ships not provided with sails, as well as the windage area of various small objects should be taken into account by increasing the windage area calculated for draught T_{\min} by 5% and the static moment of this area – by 10%.

In order to take into account the windage area of discontinuous surfaces and small objects under icing conditions, the projected lateral area and the static moment of this area, calculated for T_{\min} , shall be increased by 10% and 20% or by 7.5% and 15%, respectively, depending on the mass of ice per square metre, specified in 1.6.12.4 and 1.6.12.5. These increased values of windage areas of discontinuous surfaces and small objects, as well as their static moments shall be assumed constant for all service draughts.

1.6.7 Effect of Free Surfaces of Liquids

1.6.7.1 Ship static stability characteristics shall take into account, for all loading conditions, the effect of free surfaces of liquids on the position of the ship centre of mass, the initial metacentric height and the righting levers curves.

1.6.7.2 The effect of free surfaces of liquids shall be taken into account if the filling level in a tank is less than 98% of full condition. Free surface effects of small tanks may be disregarded in conditions specified in 1.6.7.11. But nominally full cargo tanks shall be corrected for free surface effect at 98% filling level. In doing so, the correction to initial metacentric height shall be based on the inertia moment of liquid surface at 5° of heeling angle divided by displacement, and the correction to righting lever is suggested to be on the basis of real shifting moment of cargo liquids.

1.6.7.3 Tanks which are to be taken into consideration when determining the free surface correction may be divided into two groups:

- .1** tanks with filling levels fixed (e.g. liquid cargo, water ballast);
- .2** tanks with filling levels variable (e.g. fuel oil, oils, fresh water, as well as liquid cargo and water ballast during filling/discharging operations).

Except cases specified in 1.6.7.5 and 1.6.7.6, the free surface correction taken shall be the maximum value attainable between the filling limits envisaged for each tank, consistent with operating instructions.

1.6.7.4 For tanks containing consumable liquids it shall be assumed that, for each type of liquid, at least one transverse pair or a single centreline tank has a free surface and the tank or a combination of tanks, taken into account in calculations, shall be those where the effect of free surfaces is the greatest.

1.6.7.5 Where water ballast tanks, as well as anti-rolling tanks and anti-heeling tanks are to be filled or discharged during the course of a voyage, the free surfaces effect shall be calculated for the most unfavourable stages of such operations.

1.6.7.6 For ships engaged in liquid transfer operations (to another ship), the free surface correction may be determined in accordance with the filling level in each tank in the considered stage of operation.

1.6.7.7 In determining the correction to initial metacentric height, the transverse moments of inertia of the tanks shall be calculated at 0° angle of heel and divided by displacement, according to the categories indicated in 1.6.7.3.

1.6.7.8 The righting lever curve shall be corrected by any of the following methods:

- .1** Correction based on the actual moment of fluid transfer for each angle of heel calculated; or
- .2** Correction based on the moment of inertia, calculated at 0° angle of heel, modified at each angle of heel calculated.

1.6.7.9 Corrections may be calculated according to the procedure given in 1.6.7.2

1.6.7.10 Whichever method is selected for correcting the righting lever curve, only that method shall be presented in the ship stability booklet. However, where an alternative method is described for use in manually calculated loading condition, an explanation of the differences which may be found in the results, as well as an example correction for each alternative, shall be included.

1.6.7.11 Small tanks which fulfil the following conditions need not be included in the correction:

$$M_{fs} / D_{\min} < 0.01 \text{ m}$$

where:

M_{fs} – free surface moment [tm],

D_{\min} – minimum ship displacement calculated at T_{\min} [t],

T_{\min} – minimum mean service draught of ship without cargo, with 10% stores and minimum ballast [m].

1.6.7.12 Residual liquids in empty tanks need not be taken into account in calculating the corrections, provided that the total of such residual liquids does not have a significant free surface effect.

1.6.8 Flooding Angle and Hull Watertight Integrity

1.6.8.1 Flooding angle of an intact ship shall be calculated based on the plan referred to in 1.6.5, taking account of the guidelines specified below.

1.6.8.2 Openings in the ship sides, decks, side walls, as well as in bulkheads of superstructures and deckhouses are assumed closed if their means of closure fulfil the requirements specified in *Part III – Hull Equipment* in respect of tightness, strength and effectiveness.

1.6.8.3 Openings provided with the means of closure in accordance with the tightness, strength and effectiveness requirements specified in *Part III – Hull Equipment* that during normal operation of the ship have to remain open (including openings that for operational reasons have to remain open to supply air to the engine room or emergency generator room) shall be considered as the downflooding point and the angle of their immersion shall be considered as the downflooding angle.

1.6.8.4 Small openings, such as those for passing wires and chains, tackle and anchors, as well as holes of scuppers, discharge and sanitary pipes shall not be considered as open if they submerge at an angle of heel exceeding 30°. Such openings shall be assumed open if they submerge at an angle not exceeding 30° and may be a source of significant flooding of the ship inner compartment taken into consideration in the stability cross curves calculations.

1.6.8.5 The detailed requirements concerning the ship hull watertight integrity are given in Annex 1.

1.6.9 Loading Conditions

1.6.9.1 Loading conditions for which the ship stability shall be calculated, are specified in Chapters 3 and 4 for different types of ships.

1.6.9.2 In the case of ships, for which detailed requirements are not given in Chapter 3, the stability shall be calculated for the following loading conditions:

- .1 ship in the fully loaded condition, with full stores;
- .2 ship in the fully loaded condition, with 10% stores;
- .3 ship without cargo, but with full stores;
- .4 ship without cargo and with 10% stores.

1.6.9.3 If the loading conditions, anticipated in the ship normal service, are less favourable as regards stability than those given in 1.6.9.2 or specified in Chapters 3 and 4, then for each such loading condition the stability shall also be calculated.

1.6.9.4 If there is a permanent ballast on board, its mass shall be included in the lightweight of the ship.

1.6.9.5 If, in any loading condition, provision has been made for water ballast, such ballast shall be taken into account when calculating the stability.

1.6.10 Stability Curves

1.6.10.1 For all loading conditions considered, stability curves shall be prepared with allowance for free surface corrections (see 1.6.7).

1.6.10.2 Stability curves are considered as existing only for an angle of heel corresponding to the angle of flooding. At the angle of heel exceeding the flooding angle it shall be assumed that the ship has entirely lost its stability and the stability curves cut short at this angle.

1.6.10.3 If the spread of water, coming to a superstructure through openings considered to be open, is limited to this superstructure or a part thereof, such superstructure or its part shall be considered as non-existent at the angles of heel exceeding the angle of flooding. In that case, the static stability curve shall be stepped and the dynamic stability curve – broken.

1.6.11 Stability Booklet and Stability Control Means

1.6.11.1 On board the ship there shall be available reliable information and appropriate means to enable the master to obtain, by simple and rapid processes, data on the ship stability in varying operating conditions.

1.6.11.2 Every ship shall be provided with stability booklet approved or confirmed by PRS in accordance with the provisions of 1.2.7, containing guidelines on and principles of the ship operation in compliance with the requirements of the *Rules*.

1.6.11.3 *Stability Booklet* and the related documentation shall be drawn up in the working language of the ship. If the language used is not English and the ship is engaged on international voyages, the *Stability Booklet* shall be translated into English and approved, too.

1.6.11.4 The form and scope of the *Stability Booklet* shall conform to the ship type and operating conditions.

1.6.11.5 The assessment of the ship stability shall be based on the approved diagram or print-out of the permissible values of the vertical coordinate of the ship centre of mass (KG_{\max}), determined taking into account all required criteria (specified in the present part of the *Rules*) and including the whole operation range of the ship displacement and draught.

1.6.11.6 Stability booklet shall additionally contain:

- .1** ship identification data (name of the ship, type of ship, shipyard, No. of build, date of build (alteration), the main dimensions, number of crew, number of passengers, deadweight, navigation area, symbol of class, flag, port of registry, IMO number, type of load line assigned (e.g. A, B, B-60, B+), maximum mean permissible draught corresponding to the summer freeboard assigned, maximum mean permissible draught corresponding to the summer timber freeboard assigned (if appropriate), displacement in salt water corresponding to the above draughts at the designed (level) trim, maximum permissible draught at the forward perpendicular for the minimum bow height considerations, the minimum recommended draught at the forward perpendicular.
- .2** specification of stability criteria taken for stability assessment and the ship stability short characteristics;
- .3** guidance on loading, weather and other restrictions associated with design features or ship operation, necessary to ensure the safety of the ship as regards stability;
- .4** data on the ship stability in loading conditions required by the *Rules* and in operating conditions, specified by the Owner (the plan of the ship indicating the arrangement of cargo, stores, ballast, etc., calculations of stability parameters, draughts, stability curves);

- .5 instructions for calculation and assessment of the ship stability in loading conditions other than those given in stability booklet (see 1.6.11.5); it is recommended that this instructions should contain a calculation example;
- .6 materials and data enabling to make the necessary calculations and to assess the ship stability by a rapid and simple process;
- .7 instructions concerning the proper operation of anti-rolling devices and anti-heeling system in port, as well as information on operational limits associated with the use of these arrangements and systems;
- .8 plan of permanent ballast, where provided;
- .9 inclining test report of the ship or of a sister ship, which was the basis for assuming the light ship parameters.
- .10 The inclining test report may be issued as a separate document.

Note: When considering the form and editorial quality of *Stability Booklet*, due regard shall be paid to its intended many years' usage.

1.6.11.7 As an alternative to *Stability Booklet* according to 1.6.11.6, PRS may accept a simplified, in form and scope, *Stability Booklet* containing sufficient information to enable the master to operate the ship in compliance with the applicable requirements of the present Part of the *Rules*.

1.6.11.8 *Stability Booklet* shall be drawn up on the basis of the light ship data, specified in the valid inclining test report; in the case of a ship exempted from inclining test in accordance with 1.7.5 or 1.7.6, calculations of the lightweight of the ship and coordinates of its centre, according to 1.7.3 or 1.7.7, shall be given.

1.6.11.9 When preparing GM_{\min} or KG_{\max} diagram (or table) (see 1.6.11.5) for ships which are subject to subdivision requirements, the stability criteria of a damaged ship, specified in this Part of the *Rules*, shall be taken into account.

The above-mentioned diagram (or table) shall contain information on the possible operational limits.

For passenger ships, the above-mentioned diagram shall be drawn up taking into account anticipated trims.

1.6.11.10 In the case of a passenger ship engaged on international voyages, stability booklet shall contain the requirement that prior to each departure, the ship trim and stability parameters shall be determined to ascertain compliance with the required stability criteria. Calculations covering at least 10 departures shall be maintained on board for control purposes.

1.6.11.11 As a supplement to the approved *Stability Booklet*, computer programs may be used to facilitate calculations and checking the stability.

1.6.11.12 Stability calculation programs for normal operating conditions and the possible damage shall fulfil the requirements specified in *Publication No. 66/P – Onboard Computers for Stability Calculations*. These programs are subject to PRS approval.

1.6.11.13 To facilitate the ship stability assessment in operation conditions, approved by PRS instruments for the monitoring of ship stability as well as heel angle, trim and draught of ship may be used. Application of such instruments does not permit for excluding any data or recommendations required in 1.6.11.6 from the *Stability Booklet*.

1.6.11.14 *Stability Booklet* shall contain a statement that compliance with the requirements and recommendations specified therein, neither protects a ship against the loss of stability or capsizing, irrespective of the circumstances nor absolves the master from his duty to observe the principles of good seamanship and from the responsibility for the ship safety (see 1.6.1).

1.6.12 Icing

1.6.12.1 For ships intended for winter navigation within winter seasonal zones specified in the *International Convention on Load Lines, 1966*, in addition to stability calculations for the main loading conditions, stability with regard to icing shall also be checked in accordance with this Chapter. The calculations shall take into account changes, due to icing, of displacement, height of the centre of mass and the centre of the windage area. The stability calculation under icing shall be performed for the most unfavourable, as regards stability, loading condition. When calculating the stability under icing, the mass of ice shall be regarded as an additional mass, not included in the ship deadweight.

1.6.12.2 When determining the heeling and capsizing moments for ships navigating in winter seasonal zones to the north of latitude 66°30' N and to the south of latitude 60°00' S, the conventional rates of icing shall be taken in accordance with 1.6.12.3 and 1.6.12.4.

1.6.12.3 The mass of ice per square metre of the total area of horizontal projection of exposed weather decks shall be taken equal to 30 kg. The total horizontal projection of these decks shall include horizontal projections of all exposed decks and gangways, irrespective of awnings above them. The moment due to this loading related to a horizontal plane shall be determined for heights of the centres of mass of the corresponding areas of decks and gangways.

The deck machinery, arrangements, hatch covers, etc. are assumed to be included in the projection of decks and shall not be taken into account separately.

1.6.12.4 The mass of ice per square metre of the windage area shall be taken equal to 7.5 kg at each side. The windage area and the position of its centre of mass shall be determined for draught T_{\min} in accordance with 1.6.6, but without allowance for icing.

1.6.12.5 In the areas of the winter seasonal zones, other than those specified in 1.6.12.2, the rates of icing shall be taken equal to half those specified in 1.6.12.3 and 1.6.12.4, with the exception of areas where icing may be disregarded subject to PRS consent in each particular case.

1.6.12.6 The mass of ice and the moment related to the base plane, calculated in accordance with the requirements specified in paragraphs from 1.6.12.3 to 1.6.12.5, shall be taken into account as constant, irrespective of the loading condition.

1.7 Inclining Test

1.7.1 Inclining test shall be performed for:

- .1 every new ship;
- .2 ship after modification – in accordance with 1.7.2;
- .3 ship after ballast installation – in accordance with 1.7.3;
- .4 passenger ship (in service) – periodically, in accordance with 1.7.4;
- .5 fishing vessel in service – at least once every 10 years.

1.7.2 After alteration, repair, re-equipment or modernization, the inclining test shall be performed for ships when even one of the following changes, verified by calculations, has taken place:

- deviation of the light ship displacement exceeding 2% or 2 tonnes (whichever is greater), or
- deviation of the light ship longitudinal centre of gravity exceeding 1% of the ship length L , as compared with the approved and used light ship parameters, or
- increase of the height of the light ship centre of gravity more than 2% or 4 cm (whichever is lesser).

Notwithstanding the submitted calculations, PRS may require lightweight check to be performed having regard to the ship age.

Where the deviation of the light ship properties does not exceed the above limits, the inclining test is not required, but a valid stability booklet shall be corrected for the actual light ship parameters, calculated or obtained from the lightweight check (if performed).

1.7.3 Every ship, in which permanent ballast has been installed, shall be subjected to inclining test. The inclining test need not be performed if PRS Surveyor is convinced that the mass of the ballast and the position of its centre may be reliably determined by calculations, weighing or measurement (e.g. by adding more ballast following the inclining test result).

1.7.4 Every passenger ship shall be subjected to a light ship survey, performed every 5 years. Where the deviation of the light ship displacement exceeds 2% or 2 tonnes (whichever is greater) or/and the deviation of the light ship longitudinal centre of gravity exceeds 1% of the ship length L , as compared with the approved and used light ship parameters, the inclining test shall be performed. Where the deviation of the light ship properties does not exceed the above limits, the inclining test is not required, but a valid stability booklet shall be corrected for the actual light ship parameters, obtained from the lightweight check.

1.7.5 PRS may allow the inclining test of a new ship, as required in 1.7.1.1, to be waived, provided the basic stability data are available from the inclining test of a sister ship and the newly built ship parameters are corrected for known differences in values of the light ship mass and longitudinal centre of gravity from the sister ship and the acceptable deviation of the light ship displacement, based on lightweight check, does not exceed:

- 2% for ship with a length $L \leq 50$ m,
- 1% for ship with a length $L \geq 160$ m,

(for intermediate lengths, the acceptable deviation shall be calculated by linear interpolation), and the deviation of the light ship longitudinal centre of gravity does not exceed 0.5% of the ship length L . For further calculations, the corrected light ship parameters, based on lightweight check, shall be taken. Where the above requirements are not fulfilled, the newly built ship shall be subjected to the inclining test.

Note: A sister ship is a ship built by the same shipyard according to the same technical documentation.

1.7.6 Ship or types of ships, specially designed for the carriage of one type of cargo (e.g. liquid cargo, ore), for which reference to existing data on similar ships (taking into account the ship main dimensions, the arrangement of cargo and stores) clearly indicates that sufficient metacentric height will be available in all probable loading conditions – may, at the Owner's request, be exempted from the inclining test.

1.7.7 For a ship exempted from the inclining test in accordance with 1.7.6, the lightweight of the ship and longitudinal centre of mass shall be verified and it shall be proved that the requirements of the present Part of the *Rules* are fulfilled for the height of the centre of mass of a light ship greater than the design height by 20%.

1.7.8 The ship shall be subjected to the inclining test at the final stage of construction, modification or repair, in condition, as close as possible, to that of the light ship. The mass of the subtracted elements shall not be greater than 2% of the lightweight of the ship and the mass of the superfluous elements, without shifting ballast and water ballast defined in 1.7.9 – not greater than 4% of the lightweight of the ship.

1.7.9 The ship metacentric height GM during the inclining test shall not be less than 0.2 m. For this purpose, the necessary amount of ballast shall be taken. In the case of liquid ballast, the tanks shall be fully loaded.

1.7.10 To determine the angles of heel, at least two plumb lines or at least two devices, approved by PRS, and one plumb line, shall be used.

1.7.11 When the inclining test has been performed correctly, the obtained value of the metacentric height may be taken for calculations without subtracting the probable error of the test.

The inclining test is considered to be correct when:

- .1 for each inclination, the following requirement is fulfilled:

$$|GM_i - GM_k| \leq 2\sqrt{\frac{\sum(GM_i - GM_k)^2}{n-1}} \quad (1.7.11-1)$$

GM_i – metacentric height obtained from a particular inclination, [m];

GM_k – mean metacentric height of the inclining test, [m];

$$GM_k = \frac{\sum GM_i}{n}$$

n – number of measurements taken.

The measurements, for which the above condition is not fulfilled, are not taken into account in the repeated calculations of the metacentric height GM_k ;

- .2 the probable error of the test ε calculated from the formula:

$$\varepsilon = t_{\alpha n} \sqrt{\frac{\sum(GM_i - GM_k)^2}{n(n-1)}} \quad (1.7.11-2)$$

fulfils the following conditions

$$\varepsilon \leq 0.02(1 + GM_k) \quad \text{for } GM_k \leq 2 \text{ m, or}$$

$$\varepsilon \leq 0.04 GM_k \quad \text{for } GM_k > 2 \text{ m,}$$

where:

$t_{\alpha n}$ – factor determined from Table 1.7.11.2:

Table 1.7.11.2

Factor $t_{\alpha n}$

n	6	7	8	9	10	11	12	13	14	15	16
$t_{\alpha n}$	6.9	6.0	5.4	5.0	4.8	4.6	4.5	4.3	4.2	4.1	4.0

- .3 in the most unfavourable loading condition, as regards GM or GZ_m , the following condition is fulfilled:

$$0.04 \text{ m} \leq \varepsilon \frac{D_0}{D_1} \leq \min(0.05 \text{ GM}; 0.1 \text{ GZm})$$

where:

D_0 – light ship displacement, [t];

D_1 – ship displacement in the most unfavourable loading condition, [t];

GM – corrected metacentric height, [m];

GZ_m – maximum value of the static stability righting lever within the heeling angles range up to 60°, [m].

- .4 the number of correct measurements is not less than 8.

Where more than one measurement do not satisfy the condition given in 1.7.11.1, the number of measurements to be repeated (if any) shall be agreed with PRS.

1.7.12 When the requirements of 1.7.11 are not fulfilled, then, upon PRS consent, the value of the metacentric height obtained during the inclining test, with the probable error determined in accordance with 1.7.11.2 deducted, may be taken for calculations.

1.7.13 The inclining test and verification of the lightweight of the ship (1.7.4) shall be performed in the presence of PRS Surveyor and in accordance with the principles specified in *Publication No. 6/P – Stability*.

1.8 Stability Criteria

1.8.1 With the exception of floating units, referred to in 1.8.2, the stability of ships in all loading conditions shall fulfil the following requirements:

- .1 the stability of unrestricted service ships shall be such as to fulfil the criteria specified in subchapter 2.1;
- .2 the stability of restricted service ships shall be such as to fulfil the criteria specified in subchapter 2.2;
- .3 the stability of the ship, depending on ship type, shall additionally fulfil the requirements specified in Chapter 3;
- .4 stability and the freeboard of passenger ships engaged on domestic voyages assigned additional mark **PASSENGER SHIP** and additional mark **Class A, Class B, Class C** or **Class D**, affixed to the symbol of class shall fulfil the requirements specified in *Publication No. 76/P – Stability, Subdivision and Freeboard of Passenger Ships Engaged on Domestic Voyages* based on *Directive 2009/45/EC*.

1.8.2 The stability of floating cranes, dredging fleet and pontoons shall fulfil the requirements given in Chapter 4.

1.8.3 The effect of icing shall be taken into account in stability calculations, where applicable, in accordance with the directions given in 1.6.12.

1.8.4 For ships, to which the subdivision requirements of the present Part of the *Rules* apply, the intact stability shall be such that after damage and flooding of a compartment/compartments, the damage stability criteria are fulfilled.

1.8.5 The requirements, set forth in the present Part of the *Rules*, are the minimum requirements and reflect the level of safety considered adequate, provided the general assumptions and principles applied are observed (see 1.6).

1.9 Departures from and Interpretation of Rules

1.9.1 Interpretation of the requirements and provisions, contained in *Part IV* is made solely by PRS.

1.9.2 At the designer's and/or Owner's request, PRS may, in justified cases, depart from a particular requirement or provision, provided the ship safety is not thereby impaired.

1.9.3 In respect of the requirements resulting from the provisions of international conventions and national regulations, departure therefrom may be accepted only in cases and in accordance with the procedure specified in the particular convention or regulations.

1.9.4 For floating objects incorporating novel design features with respect to buoyancy and stability, the valid requirements of the present Part of the *Rules* may, subject to PRS consent in each particular case, be applied within reasonable scope; in each particular case, such novel design features are subject to the assessment with respect to safety according to the current state of art.

1.9.5 Where, with respect to any ship complying with the requirements of the present Part of the *Rules*, any doubt arises regarding her stability or subdivision, PRS may apply additional requirements to such a ship.

1.9.6 Where deemed necessary, PRS may enter respective records on operational limits in the approved documentation and the documents issued.

1.10 Passage beyond Specified Navigation Area

1.10.1 Ship stability during a passage beyond navigation area specified in the *Certificate of Class* shall fulfil the stability requirements applicable to the navigation area through which the passage is to be undertaken.

1.10.2 Unless a ship fulfils the stability requirements mentioned in 1.10.1, then, subject to PRS consent in each particular case, she may be permitted to undertake the passage, provided weather restrictions are applied.

1.11 Required Bow Height

1.11.1 The required bow height shall not be less than determined in accordance with Regulation 39 of the *International Convention on Load Lines – 1966* (see Appendix 7).

1.12 Ballast water exchange

1.12.1 Ballast water exchange operations shall be performed in accordance with the instructions in the approved *Ballast Water Management Plan*.

1.13 Freeboard

1.13.1 For ships subject to the *International Convention on Load Lines, 1966* the freeboard shall be determined in accordance with *Annex I* to that *Convention* taking account of the latest amendments and IACS interpretations UILL.

2 BASIC REQUIREMENTS AND CRITERIA

2.1 Unrestricted Service Ships

2.1.1 General

The requirements specified in this sub-chapter are based on the stability criteria contained in the *International Code on Intact Stability – 2008 IS Code*, IMO (Resolution MSC.267(85)) adopted on 4 December 2008 and corrigendum introduced by IMO document MSC 85/26/Add.1/Corr.3/Rev.1 adopted on 09 October 2018.

2.1.1.1 The requirements of the present sub-chapter apply to ships operating in unrestricted navigation area (see also 1.2.2).

2.1.2 Weather Criterion

2.1.2.1 The ship stability with respect to weather criterion is considered sufficient if the ship is able to withstand the combined effects of beam wind and rolling in conditions specified below (Fig. 2.1.2.2):

- .1 the ship is subjected to a steady wind pressure acting perpendicular to the ship centre plane which results in a steady wind heeling lever l_{w1} ;
- .2 from the initial angle of heel Θ_0 under action of steady wind, the ship, due to wave action, rolls to an angle of roll Θ_1 to windward;
- .3 the ship is then subjected to a gust wind pressure which results in a gust wind heeling lever l_{w2} .

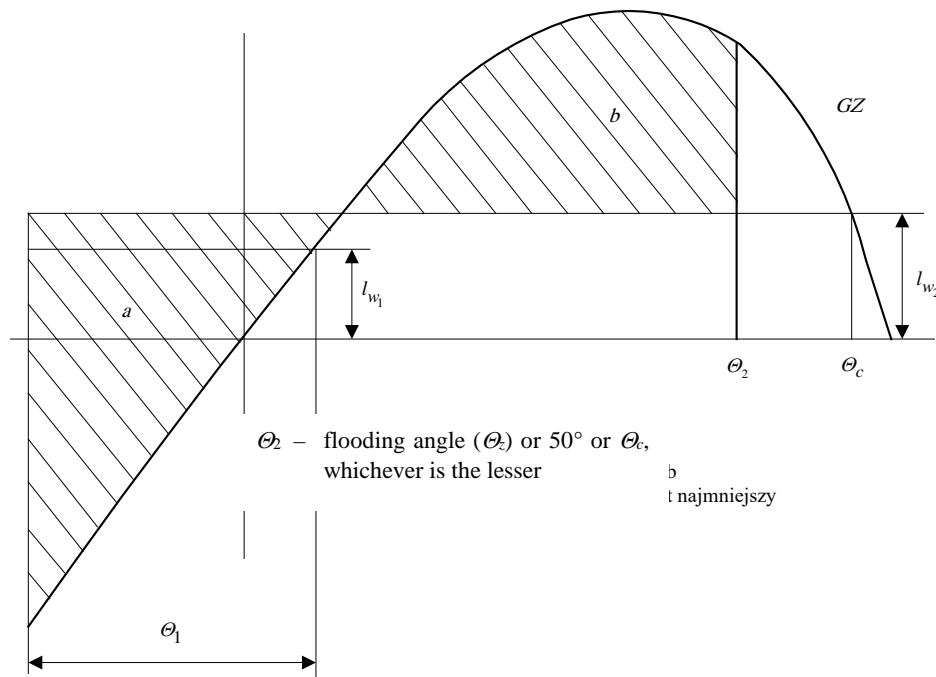

Fig. 2.1.2.2

2.1.2.2 The ship stability satisfies the weather criterion if area “b” is equal to or greater than area “a” (Fig. 2.1.2.2). Area “b” is the area between GZ curve and the straight line l_{w2} , measured between the angle of GZ curve and l_{w2} first intercept up to the angle of 50° or the angle of flooding Θ_c , or up to the angle of GZ curve and l_{w2} second intercept, whichever is the lesser.

Area “a” is the area between GZ curve and the straight line l_{w1} , measured between the angle of roll Θ_1 , decreased by the angle of heel under action of steady wind Θ_0 (the angle of intercept between GZ curve and l_{w1}) and the angle of GZ curve and l_{w1} first intercept.

2.1.2.3 The initial angle of heel (Θ_0) under action of steady wind shall not be greater than 16° or 0.8 the angle at which deck edge immerses, whichever is the lesser.

2.1.2.4 The values of wind heeling levers l_{w1} and l_{w2} , assumed constant at all angles of heel, shall be calculated as follows:

- .1** wind heeling lever l_{w1} shall be calculated from the formula:

$$l_{w1} = \frac{q_v F_w z_v}{1000 g D} \quad [\text{m}] \quad (2.1.2.4-1)$$

where:

q_v = 504 Pa – wind pressure; for fishing vessels – see 2.1.2.5;

F_w – windage area (see 1.6.6), [m²];

z_v – vertical distance from the centre of windage to the centre of the underwater lateral area or approximately to half the ship draught, [m];

D – ship displacement, [t];

g – 9.81 m/s²;

- .2** wind heeling lever l_{w2} shall be calculated from the formula:

$$l_{w2} = 1.5 l_{w1} \quad [\text{m}] \quad (2.1.2.4-2)$$

2.1.2.5 For fishing vessels of 24 to 45 m in length L , the wind pressure q_v in formula 2.1.2.4-1 shall be taken in accordance with Table 2.1.2.5, depending on the distance from the centre of the windage area to the waterline.

Table 2.1.2.5
Wind pressure q_v

z [m]	1.0	2.0	3.0	4.0	5.0	≥ 6.0
q_v [Pa]	316	386	429	460	485	504

The angle of roll shall be calculated from the formula:

$$\theta_1 = 109 \cdot k \cdot X_1 X_2 \sqrt{r S} \quad [\text{degrees}] \quad (2.1.2.6-1)$$

where:

X_1 – factor, to be taken from Table 2.1.2.6-2;

X_2 – factor, to be taken from Table 2.1.2.6-3;

k – factor, to be taken as follows:

k = 1.0 for round-bilged ships having no bilge or bar keels,

k = 0.7 for ships with sharp bilge,

k = as shown in Table 2.1.2.6-1 for ships having bilge keels, a bar keel or both, depending on F_k/L_0B ratio;

(F_k – total overall area of bilge keels or area of the lateral projection of the bar keel, or sum of these areas, [m²]);

$$r = 0.73 + 0.6(KG - T_{sr})/T_{sr} \quad (2.1.2.6-2)$$

where:

KG – distance between the ship centre of mass and the centre plane, [m];

T_{sr} – mean draught of the ship in the given loading condition, [m];

S – factor, to be taken from Table 2.1.2.6-4, depending on the ship rolling T_θ , determined from the formula:

$$T_\theta = \frac{2C \times B}{\sqrt{GM}} \quad [\text{s}] \quad (2.1.2.6-3)$$

where:

C = $0.373 + 0.023 (B/T_{sr}) - 0.043 (L_0/100)$;

GM – corrected metacentric height, [m].

Table 2.1.2.6-1
Factor k

F_k/L_0B [%]	0	1.0	1.5	2.0	2.5	3.0	3.5	≥ 4.0
k	1.00	0.98	0.95	0.88	0.79	0.74	0.72	0.70

Table 2.1.2.6-2
Factor X_1

B/T_{sr}	≤ 2.4	2.5	2.6	2.7	2.8	2.9	3.0	3.1	3.2	3.3	3.4	≥ 3.5
X_1	1.00	0.98	0.96	0.95	0.93	0.91	0.90	0.88	0.86	0.84	0.82	0.80

Table 2.1.2.6-3
Factor X_2

δ	≤ 0.45	0.50	0.55	0.60	0.65	≥ 0.70
X_2	0.75	0.82	0.89	0.95	0.97	1.00

δ – block coefficient for draught T_{sr}

Table 2.1.2.6.4
Factor S

T_θ [s]	≤ 6	7	8	12	14	16	18	≥ 20
S	0.100	0.098	0.093	0.065	0.053	0.044	0.038	0.035

Note: Intermediate values in Tables 2.1.2.6-1, 2.1.2.6-2, 2.1.2.6-3 and 2.1.2.6-4 shall be obtained by linear interpolation.

2.1.2.6 The angle of roll of a ship fitted with anti-rolling arrangements shall be determined in accordance with 2.1.2.6, without taking into account the operation of these arrangements.

2.1.3 Static Stability Curve

2.1.3.1 The static stability curve shall fulfil the following requirements:

- .1** the area under the righting levers curve shall not be less than 0.055 m-rad up to 30° angle of heel and not less than 0.090 m-rad up to 40° angle of heel and the area under the righting lever curve between the angles of heel of 30° and 40° shall not be less than 0.030 m-rad;
- .2** the value of the static stability righting lever shall not be less than 0.20 m at an angle of heel equal to or greater than 30°;
- .3** the maximum value of the static stability righting lever curve shall occur at an angle of heel equal to or greater than 30°; this angle may be decreased in accordance with 2.2.2.3;
- .4** it is recommended that the range of the positive static stability shall not be less than 60°; this range may be less than 60° but not less than 50°, provided that the value of the righting lever, required in .2, is increased by 0.01 m for each 1° of the range decrease below 60°.

2.1.3.2 The angle of flooding shall not be less than the angle of the positive static stability range, required in 2.1.3.1.4.

2.1.3.3 For ships loaded with timber deck cargo and provided that the cargo extends longitudinally between superstructures (where there is no limiting superstructure at the after end, the timber cargo shall extend at least to the after end of the aftermost hatchway) and transversely for the full beam of the ship, with due regard to allowance for a rounded gunwale not exceeding 4% of the ship deck breadth and/or the securing of the supporting uprights and that the cargo remains securely fixed at large angles of heel, the requirements of 2.1.3.1.1. to 2.1.3.1.4 concerning static stability may, upon PRS consent, be substituted by the following requirements:

- .1 the area under the static stability righting lever curve shall not be less than 0.08 m-rad up to 40° angle of heel;
- .2 the maximum value of the static stability righting lever curve shall not be less than 0.25 m.

2.1.3.4 The parameters of the static stability righting lever curve, required in 2.1.3.1 and 2.1.3.3, shall be maintained after correction for free surfaces effect in accordance with 1.6.7.

2.1.4 Metacentric Height

2.1.4.1 The corrected metacentric height shall not be less than:

- .1 for container ships – the value determined in 3.3.4,
- .2 for ships carrying containers on deck – the value determined in 3.2.6,
- .3 for timber carriers – the value determined in 3.5.4,
- .4 for fishing vessels – the value determined in 3.7.5,
- .5 for the remaining ship types in each loading condition – not less than 0.15 m.

2.1.4.2 In the “light ship” loading condition, the metacentric height is subject to special consideration by PRS.

2.2 Restricted Service Ships

2.2.1 Weather Criterion

2.2.1.1 The stability of ships, with respect to weather criterion, is considered sufficient if in all service loading conditions the dynamically acting wind heeling moment M_w , taking into account the ship rolling, is equal to or less than the capsizing moment M_{kr} , i.e. the following dependence is satisfied:

$$K = \frac{M_{kr}}{M_w} \geq 1 \quad (2.2.1.1)$$

where:

K – weather criterion factor.

2.2.1.2 The wind heeling moment shall be calculated in accordance with 2.2.1.5, taking into account the ship navigation area.

2.2.1.3 In the present Chapter, restricted areas of navigation **I**, **II** and **III**, described in details in *Part I – Classification Regulations*.

In the case of a ship assigned a restricted service mark, affixed to the symbol of class, an entry on the navigation area and on the possible further constraints shall be made in stability booklet; in the case of a passenger ship – additionally in the list of all limitations on the operation required by SOLAS V/30.

2.2.1.4 The value of the weather criterion K for ships intended for operation in heavy seas (e.g. weather observation ships) will be specially considered by PRS; it is recommended that this value should not be less than 1.5.

2.2.1.5 The wind heeling moment shall be calculated from the formula:

$$M_w = 0.001q_w F_w z \quad [\text{kNm}] \quad (2.2.1.5)$$

q_w – wind pressure, [Pa], according to Table 2.2.1.5;

F_w – windage area, [m²], (see 1.6.6);

z – distance between the centre of windage area and the waterline plane (see 1.6.6.2), [m].

The value of the wind heeling moment shall be taken constant within the full range of the ship inclination.

The value of the wind pressure q_w shall be taken in accordance with Table 2.2.1.5, depending on the ship navigation area and the position of the centre of windage area (z). For ships of restricted service **III**, the value of the wind pressure shall be agreed with PRS.

2.2.1.6 The method of determining the capsizing moment M_{kr} shall be accepted by PRS. The recommended method of determining the capsizing moment is given in *Publication No. 6/P – Stability*.

Table 2.2.1.5
Wind pressure q_w [Pa]

Navigation area \ z[m]	0.5	1.0	2.0	3.0	4.0	5.0	6.0	7.0 and above
Restricted I	365	400	489	551	595	628	662	689
Restricted II	177	194	237	267	288	305	321	334

2.2.1.7 The angle of roll shall be calculated from the formula:

$$\Theta_a = k X_1 X_2 Y \quad [\text{degrees}] \quad (2.2.1.7)$$

where:

k – factor, to be taken as follows:

$k = 1$ for round-bilged ships having no bilge or bar keels,

$k = 0.7$ for ships with sharp bilge,

$k =$ as shown in Table 2.1.2.6–1 for ships with bilge keels, a bar keel or both, depending on F_k/L_0B ratio;

F_k – total area of bilge keels or the lateral projection of the bar keel, or sum of these areas, [m²];

L_0 – ship design length, [m];

B – ship breadth, [m];

X_1 – factor, to be taken from Table 2.1.2.6-2;

X_2 – factor, to be taken from Table 2.1.2.6-3;

Y – coefficient, to be taken from Table 2.2.1.7;

GM – metacentric height in the considered loading condition with the free surface correction, [m].

Table 2.2.1.7
Coefficient Y [degrees]

$\frac{\sqrt{GM}}{B}$	≤ 0.04	0.05	0.06	0.07	0.08	0.09	0.10	0.11	0.12	≥ 0.13
Restricted navigation areas I and II	16.0	17.0	19.7	22.8	25.4	27.6	29.2	30.5	31.4	32.0

2.2.1.8 Allowance for bilge keels in the angle of roll calculations of ships with ice strengthenings shall be agreed with PRS.

2.2.1.9 The angle of roll of ships fitted with anti-rolling arrangements, other than bilge keels, shall be determined in accordance with 2.2.1.7, without taking into account the operation of these arrangements. It shall be proved, however, that the stability criteria are satisfied during the arrangements operation.

2.2.1.10 Allowance for the operation of anti-rolling arrangements in the angle of roll calculations is subject to PRS agreement in each particular case.

2.2.2 Static Stability Curve

2.2.2.1 The maximum static stability righting lever GZ_m shall not be less than 0.20 m at the angle of heel Θ_m not less than 30°. It is recommended that the range of the positive static stability should be not less than 60°; this range may be less than 60° but not less than 50°, provided that the value of the righting lever, required 0.2 m, is increased by 0.01 m for each 1° of the range decrease below 60°.

If the curve of static stability has two maxima, the first maximum from the upright position shall occur at the angle of heel not less than 25°.

2.2.2.2 The range of static stability curve, calculated with regard to icing in accordance with 1.6.12, shall not be less than 55° and the maximum static stability righting lever of restricted service ships shall not be less than 0.2 m at the angle of heel not less than 25°.

For ships with $B/H > 2$ ratio, the required range of static stability curve under icing may be decreased by half of $\Delta\Theta$, determined from formula 2.2.2.3-1.

2.2.2.3 Ships with $B/H > 2$ ratio may have the range of the positive static stability curve and the angle corresponding to the first maximum of the curve less than those required in 2.2.2.1 by the following values:

- .1 the range of curve – by the value $\Delta\Theta$, determined, depending on B/H ratio and the weather criterion K , from the following formula:

$$\Delta\Theta = 40^\circ \left(\frac{B}{H} - 2 \right) (K - 1) \quad [\text{degrees}] \quad (2.2.2.3-1)$$

where $B/H > 2.5$ or $K > 1.5$, the values of $B/H = 2.5$, $K = 1.5$, shall be taken for calculations respectively; the value of $\Delta\Theta$ shall be rounded off to the whole number;

- .2 the angle corresponding to the first maximum of the static stability curve – by half of $\Delta\Theta$, where:

H – moulded depth of the ship applied in stability cross curves calculations, [m].

- .3 for ships that are of wide beam and small depth, indicatively $B/H \geq 2.5$, the Administration may apply the following alternative criteria:
 - the maximum righting lever (GZ) shall occur at an angle of heel not less than 15°;
 - the area under the curve of righting levers (GZ curve) shall not be less than 0.070 m·rad up to an angle of 15° when the maximum righting lever (GZ) occurs at 15° and 0.055 m·rad up to an angle of 30° or above. Where the maximum righting lever (GZ) occurs at angles between 15° and 30°, the corresponding area under the righting lever curve GZ shall be:

$$0.055 + 0.001 \times (30^\circ - \Theta_m) \quad [\text{m} \cdot \text{rad}]. \quad (2.2.2.3-3)$$

2.2.2.4 Parameters of the static stability curves, required in 2.2.2.1 to 2.2.2.3, shall be fulfilled taking into account the free surface correction in accordance with 1.6.7.

2.2.2.5 The angle of flooding shall not be less than the required values of the positive static stability range, determined in 2.2.2.1 and 2.2.2.3.

2.2.3 Metacentric Height

2.2.3.1 The corrected metacentric height shall not be less than:

- .1 for container ships – the value determined in 3.3.4,
- .2 for ships carrying containers on deck – the value determined in 3.2.6,
- .3 for timber carriers – the value determined in 3.5.4,
- .4 for fishing vessels – the value determined in 3.7.5,
- .5 for the remaining ship types in each loading condition – not less than 0.15 m.

2.2.3.2 In the “light ship” loading condition, the metacentric height is subject to special consideration by PRS.

3 STABILITY – DETAILED REQUIREMENTS FOR PARTICULAR TYPES OF SHIPS

3.1 Passenger Ships

3.1.1 The requirements of the present sub-chapter apply to passenger ships assigned the additional mark **PASSENGER SHIP**, affixed to the symbol of class.

In addition the passenger ships shall fulfil the provisions of European Parliament and *Council Directive 2009/45/EC* of 6 May 2009.

3.1.2 The stability of passenger ships shall be calculated for the following loading conditions:

- .1** ship in the fully loaded condition, with full complement of class and unberthed passengers and their luggage, with full stores; the possibility of water ballasting shall be agreed with PRS;
- .2** ship in the fully loaded condition, with full complement of class and unberthed passengers and their luggage, with 10% stores;
- .3** ship in the fully loaded condition, with full complement of class and unberthed passengers and their luggage, with 50% stores;
- .4** ship without cargo, with full complement of class and unberthed passengers and their luggage, with full stores;
- .5** ship without cargo, with full complement of class and unberthed passengers and their luggage, with 10% stores;
- .6** ship without cargo and passengers, with full stores;
- .7** ship without cargo and passengers, with 10% stores.

3.1.3 When calculating stability, class passengers shall be assumed to be in their accommodation spaces and unberthed passengers – on appropriate decks. The arrangement of passengers' luggage and its mass are subject to PRS consideration in each particular case. The stowage of cargo in holds, 'tweendecks' and on decks shall be assumed as for normal service conditions.

Where ship ballasting is necessary, the stability shall be calculated with an allowance for water ballast.

The stability with an allowance for icing shall be calculated with no passengers on open decks.

3.1.4 The initial stability of passenger ships shall be such that in the possible case of crowding of passengers to one side on the uppermost deck accessible to passengers (as near to the bulwark as possible), the angle of static heel is not greater than the angle at which the continuous upper deck immerses or the angle at which the bilge comes out of water, whichever is the lesser; in no case is the angle of static heel to exceed 10°.

3.1.5 The angle of heel due to the effect of the heeling moment M_{hc} as a result of turning (see 3.1.9) shall not exceed the angle at which the upper deck immerses or the angle at which the bilge comes out of water, whichever is the lesser; in no case is the angle of heel to exceed 10°.

3.1.6 When determining the heeling moment due to crowding of passengers to one side, the mass of each passenger shall be assumed to be 0.075 ton, the height of the centre of mass for standing passengers shall be equal to 1.1 m above the deck, that for sitting passengers – 0.3 m above the seats; the passengers distribution density: 4 persons per square metre of the deck area.

3.1.7 When determining the area where crowding of passengers is permitted, the passages between seats and the areas of narrow external passages between the deckhouse and the bulwark or railing up to 0.7 m wide shall be taken for calculations with the factor 0.5.

3.1.8 When establishing distribution of passengers in order to determine the heeling moment M_{hp} , it shall be assumed that the normal ship service conditions with an allowance for the position of the equipment and machinery are maintained and the principles governing access of passengers to a particular deck area are observed; diagram of the assumed distribution of the crowding passengers shall be included in stability booklet.

3.1.9 The heeling moment due to turning shall be determined from the formula:

$$M_{hc} = 0.24 \frac{Dv_0^2}{L_0} \left(KG - \frac{T_{sr}}{2} \right) \quad [\text{kNm}] \quad (3.1.9)$$

D – displacement, [t];

v_0 – maximum service speed, [m/s];

L_0 – design length of the ship, [m];

KG – height of the centre of mass (with the free surface correction), [m];

T_{sr} – mean draught in the given loading condition, [m].

3.1.10 The angle of heel caused by turning and the angle of heel caused by crowding of passengers shall be calculated without allowance for the action of wind, rolling and icing, but taking into account the effect of free surfaces of liquids in tanks in accordance with the requirements given in 1.6.7.

3.1.11 Stability and subdivision booklet of a ro-ro passenger ship shall additionally contain the following:

- .1 a note indicating the importance of securing and maintaining all closures watertight considering the possibility of a rapid loss of stability which may result when water enters the ro-ro deck;
- .2 information concerning maintaining the ship steerability in extreme weather conditions that may be encountered in the navigation area of the ship.

The results of tests confirming the above information shall be submitted to the PRS Head Office for information.

3.1.12 Passenger ships which are assigned an additional mark **SRP** in the symbol of class shall additionally comply with the requirements specified in para. 7 of *Publication No. 66/P – Onboard Computers for Stability Calculations*.

3.2 Dry Cargo Ships

3.2.1 The requirements of the present sub-chapter apply to ships assigned one of additional marks: **GENERAL CARGO SHIP, FERRY, RO-RO SHIP, BULK CARRIER, ORE CARRIER, CEMENT CARRIER, CONTAINER SHIP, REEFER CARRIER, LIVESTOCK CARRIER, SUPPLY VESSEL, ACC**, affixed to the symbol of class.

3.2.2 The stability of the above-mentioned ships shall be calculated for the following loading conditions:

- .1 ship having a draught to the summer load waterline with cargo homogeneously distributed in the holds, tweendecks, coaming spaces and trunks of cargo hatches, with full stores, but without water ballast;
- .2 ship in the same condition as in .1, but with 10% stores and water ballast, where necessary;
- .3 ship without cargo, but with full stores;
- .4 ship in the same condition as in .3, but with 10% stores;
- .5 for bulk carriers with notations **BC-A, BC-B** or **BC-C**, the stability shall be checked for all loading conditions specified in 20.9.3 of *Part II – Hull of the Rules*;
- .6 light ship;
- .7 docking.

3.2.3 Where in loading conditions, specified in 3.2.2.3 and 3.2.2.4, cargo holds are used to take an additional water ballast, the ship stability with water ballast in these holds shall be checked. The effect of free surfaces in the ship tanks shall be taken into account in accordance with 1.6.7; in holds with water ballast – assuming the actual filling of the holds.

3.2.4 In the case of loading conditions different from those above, specified by the Owner (kind of cargo, special features of operation routes, etc.), the ship stability shall also be calculated for those conditions, with full and 10% stores and with water ballast, where necessary.

3.2.5 Where ships are normally engaged in the carriage of deck cargoes, the stability shall be calculated for the following additional conditions:

- .1 ship loaded to the summer load waterline, with holds and tweendecks filled with homogeneous cargo, with deck cargo, full stores and water ballast, where necessary;
- .2 ship in the same condition as in .1, but with 10% stores.

3.2.6 The corrected metacentric height of ships loaded with containers on deck shall not be less than that determined in 3.3.4.

3.2.7 For each loading condition, stability booklet shall contain:

- .1 a drawing (sketch) of the ship indicating, pictorially, the main items of the deadweight included in the displacement,
- .2 a table showing the light ship particulars, the distribution of all components of the deadweight, the positions of their centres, calculated static moments and a summation giving the result which should show the full displacement mass and the position of its centre,
- .3 tables listing the free surface effects of liquids in all tanks which may be partially filled,
- .4 a diagram showing the curve of righting levers GZ , corrected for free surface effects, plotted against angle of inclination. The scales used shall be same for each loading condition,
- .5 a summary of the appropriate loading condition giving:
 - displacement in salt water (at stated density),
 - corresponding draught at longitudinal centre of floatation,
 - corresponding draught at freeboard mark,
 - moment to change trim one unit,
 - longitudinal and transverse positions of centre of buoyancy,
 - longitudinal and transverse positions of centre of gravity,
 - trimming lever,
 - longitudinal position of centre of floatation,
 - trim at forward perpendicular,
 - trim at after perpendicular,
 - draught at forward perpendicular,
 - draught at after perpendicular,
 - draught at the forward draught mark,
 - draught at the aft draught mark,
 - mean draught amidships,
 - the total free surface effects,
 - the vertical position of the transverse metacentre,
 - the vertical position of the ship centre of gravity corrected for free surface effects,
 - the vertical position of the ship centre of gravity uncorrected for free surface effects,
 - a statement giving the limiting value or values of stability parameters for each stability criterion together with corresponding values achieved.

3.2.8 Ships assigned one of the additional marks: **BULK CARRIER**, **ORE CARRIER** or **CEMENT CARRIER**, affixed to the symbol of class, with the length $L < 150$ m shall be provided with loading instrument in accordance with *Publication No. 16/P – Loading Guidance Information*.

The loading instrument shall be additionally capable of computing intact ship stability in accordance with *Publication No. 66/P – Onboard Computers for Stability Calculations*.

3.3 Container Ships

3.3.1 The requirements of the present sub-chapter apply to ships assigned one of additional marks: **CONTAINER SHIP**, **ACC**, affixed to the symbol of class.

3.3.2 The stability shall be calculated for the following loading conditions:

- .1 ship with the maximum number of containers loaded in such a way that in each pile the ratio of mass of the cargo in the container to the maximum gross mass of each container is constant and results from allowance of the permissible loading of the ship structure caused by containers

and their lashing; with full stores and water ballast, where necessary; the ship draught cannot be greater than that corresponding to the summer load waterline; the top pile containers may be empty;

- .2 ship in the same loading condition as in .1, but with 10% stores;
- .3 ship with the maximum number of containers having a mass of cargo in the container equal to 0.6 of the maximum gross mass for a container of a given type, taking into account the permissible loading of the ship structure caused by containers and their lashing; with full stores and water ballast (where necessary);
- .4 ship in the same loading condition as in .3, but with 10% stores;
- .5 ship with containers having a mass of cargo in each container maximum for a given type of container, taking into account the permissible loading of the ship structure caused by containers and their lashing; with full stores and water ballast (where necessary); the ship draught cannot be greater than that corresponding to the summer load waterline;
- .6 ship in the same loading condition as in .5, but with 10% stores;
- .7 ship with the maximum permissible number of empty containers, with full stores and with water ballast;
- .8 ship in the same loading condition as in .7, but with 10% stores;
- .9 ship without cargo, with full stores;
- .10 ship without cargo, but with 10% stores.

3.3.3 Where loading conditions, other than those specified in 3.3.2, are anticipated by the Owner, stability shall also be calculated for such loading conditions – with full stores and 10% of stores and with water ballast, where necessary.

3.3.4 The corrected metacentric height in the loading condition with containers on deck shall not be less than 0.15 m. It is recommended that this height should be not less than 0.20 m.

3.3.5 In stability calculations of container ships, the position of the centre of mass of each container shall be taken at half of the container height. Where a ship is provided with the initial stability control arrangements, approved by PRS, the position of the centre of mass of each container may be taken at the height not less than 0.45 the container height.

3.3.6 The stability of container ships, in any loading condition with containers, shall be such that the angle of static heel due to turning or to the effect of wind is not greater than half the angle at which the upper deck immerses; in no case is the angle of heel to be greater than 15°.

3.3.7 The heeling moment due to turning shall be calculated from formula 3.1.9.

3.3.8 The heeling moment due to the effect of the wind, required to determine the angle of heel in accordance with 3.3.6, shall be calculated from formula 2.2.1.5, assuming the value of q_w equal to 0.6 times the values given in Table 2.2.1.5 for the relevant area of navigation.

3.3.9 The angle of static heel due to turning or to the effect of the wind shall be determined without allowance for icing, but with correction for the free surface effect of liquids in accordance with 1.6.7.

3.3.10 Container ships shall be provided with tanks enabling the control of the angle of heel during cargo handling operations.

3.3.11 Stability booklet shall contain an example of calculation made for one of the most unfavourable permissible loading conditions likely to occur in service when the ship is loaded with containers of different mass.

3.4 Tankers

3.4.1 The requirements of this sub-chapter apply to ships assigned one of additional marks: **CRUDE OIL TANKER, PRODUCT CARRIER A, PRODUCT CARRIER B, TANKER FOR ..., OIL RECOVERY VESSEL**, affixed to the symbol of class.

3.4.2 All new chemical tankers shall be fitted with a stability instrument capable of verifying compliance with the intact and damage stability requirements approved by the Administration.

Exemptions from this requirement and the schedule for the requirement regarding this stability instrument to be implemented on the existing tankers are provided in IMO Resolution MEPC.248 (66).

3.4.3 The stability of tankers shall be calculated for the following loading conditions:

- .1 ship loaded to the summer load waterline, in fully loaded condition and with full stores;
- .2 ship in fully loaded condition and with 10% stores;
- .3 ship without cargo, with full stores;
- .4 ship without cargo, but with 10% stores.

3.4.4 For ships assigned **OIL RECOVERY VESSEL** mark, the stability shall be additionally calculated for the ship loading condition with 75 % of cargo, with free surfaces in tanks for each kind of cargo and with 50% stores, but without water ballast. The free surface effect in tanks for stores and in cargo tanks shall be determined in accordance with the requirements of 1.6.7.

3.4.5 The requirements of 3.4.3 are applicable to all ships intended for oil recovery in oil spillage area.

3.4.6 Stability characteristics of tankers provided with gutter bars installed on the weather deck in way of cargo manifold shall take into account the free surface effect caused by liquids contained by the gutter bars. Where the gutter bars installed are greater than 300 mm in height, they shall be treated as bulwarks with freeing ports (in accordance with regulation 24 of the *International Convention on Load Lines, 1966*) and effective closures provided for use during loading and discharging operations.

3.4.7 Tankers of 5000 tonnes deadweight and above shall fulfil the requirements of regulation 27 of Annex I to *MARPOL 73/78. Unified interpretation No. 45* related to regulation 27 of Annex I as well as *IACS Unified Interpretations UI MPC 11 and MPC 129* or *IMO Unified Interpretations MEPC.1/Circ.867* shall be fulfilled.

3.4.8 It is recommended that the masters of tankers not subject to the requirements of the above-mentioned regulation 27 should be supplied with instructions for liquid transfer operations to fulfil stability criteria, specified in the said regulation. Such instructions shall be prepared in accordance with regulation 27.

3.5 Timber Carriers

3.5.1 The requirements of the present sub-chapter apply to ships assigned an additional mark **TIMBER**, affixed to the symbol of class, as well as to ships with the entry: "ship adapted for the carriage of timber deck cargoes" in the Certificate of Class.

3.5.2 The stability of ships intended for the carriage of timber deck cargoes shall be calculated for the following loading conditions:

- .1 ship loaded to the summer timber load waterline carrying timber cargo in holds and on deck with a prescribed stowage factor; where the stowage factor is not specified, the factor equal to 2.32 m³/t shall be taken; with full stores, but without water ballast.
If, in service conditions, the ship draught is less than the max. allowable draught determined by the freeboard mark, calculations shall also be made for such a draught.
- .2 ship in the same loading condition as in .1, but with 10% stores;
- .3 ship with timber cargo having the least assumed stowage factor (for the heaviest timber cargo) in holds and on deck; with full stores;
- .4 ship in the same loading condition as in .3, but with 10% stores;
- .5 ship without cargo, with full stores;
- .6 ship without cargo, but with 10% stores.

3.5.3 The Arrangement, stowing and securing of timber deck cargo shall fulfil at least the requirements specified in *Code of Safe Practice for Ships Carrying Timber Deck Cargoes, 2011* (i.e. 2011 TDC Code issued by IMO) – see *Publication No.32/P – Requirements Concerning Stowage and Lashing of Cargoes on Sea-going Ships*.

3.5.4 Corrected metacentric height of a ship loaded with timber cargo shall not be less than 0.10 m throughout the whole voyage, taking also in account the water absorption and icing.

Corrected metacentric height should preferably not exceed 3% of the breadth of the vessel, provided that the remaining stability criteria are met.

3.5.5 In ships carrying timber deck cargo, arranged in accordance with 3.5.3, the lever of dynamic stability shall not be less than 0.08 m-rad at the angle of heel 40°.

3.5.6 When the effect of icing is calculated, the upper surface of timber deck shall be regarded as deck and its side surfaces above the bulwark – as part of the design windage area. The ice accretion mass w [kg/m²] shall be taken as follows:

$$w = 30 \cdot \frac{2,3 \cdot (15,2 \cdot L - 351,8)}{l_{wb}} \cdot f_d \cdot \frac{l_{dz}}{0,16 \cdot L} \quad (3.5.6)$$

where:

f_d – timber lashing factor = 1.2

L – length of ship, [m],

l_{wb} – freeboard height, [mm],

l_{dz} – the distance from the longitudinal position at which the maximum breadth occurs on a waterline located 0.5 metres below the freeboard deck at side to the foremost point of the bow on that waterline, [m].

3.5.6.1 The effect of ice accretion on timber on ship stability shall be determined for the cases indicated in Fig. 3.5.6.1.

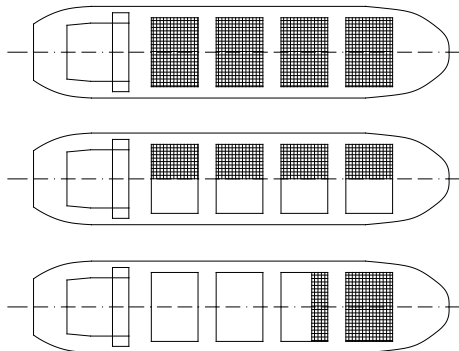

Fig. 3.5.6.1

3.5.7 For ships loaded with timber deck cargo, intended to be operated in areas, in which icing shall not be taken into account, as well as those navigating in summer within winter seasonal zones, the stability shall be calculated for the most unfavourable loading condition from among those specified in 3.5.2.1 to 3.5.2.4, having regard to the possible increase of the timber deck cargo weight due to water absorption.

Where data on the extent of water absorption by different kinds of timber are not available, it is recommended that the increase in mass of the deck cargo should be assumed equal to 10%. The increase in mass shall be regarded as a mass additional to the ship deadweight. It shall be assumed that the centre of mass of timber deck cargo does not change due to water absorption.

3.5.8 When calculating the cross curves of stability of ships intended for the carriage of timber deck cargo, the volume of timber deck cargo may be taken into account, but only to such a height over the deck which does not exceed the forecastle height.

The following shall be taken for calculations:

- 1** permeability of the timber cargo not less than 0.25; the permeability may be taken into account in calculations by assuming an equivalent length of the timber cargo;

- .2 the actual width of the timber cargo, having regard to limitations of the width by a bulwark structure, securing elements, etc.

3.5.9 A ship intended for the carriage of timber deck cargo shall be provided with the approved plan of timber deck cargo stowage and securing; stowage and securing of the cargo, presented on the plan, shall be in accordance with the provisions of the *Code*, referred to in 3.5.3, having regard to the kind of the carried timber; the plan shall be supplemented with the *Code*, in the same language as that of the plan.

3.5.10 If a ship, intended for the carriage of timber, is to be used for the carriage of other cargoes, the stability shall be calculated according to the requirements of 3.2. In such case, the calculation of cross curves of stability and the windage area shall be made without allowance for the timber deck cargo.

3.6 Special Purpose Ships

3.6.1 The requirements of the present sub-chapter apply to ships assigned an additional mark **RESEARCH SHIP**, **TRAINING SHIP** or assigned another mark indicating the ship type in accordance with para. 3.4.2.4 of *Part I – Classification Regulations*, affixed to the symbol of class.

3.6.2 The stability of special purpose ships shall fulfil the requirements specified in Chapter 2.5 of Part B of the *International Code on Intact Stability – 2008 IS Code*.

3.7 Fishing Vessels

3.7.1 The requirements of this sub-chapter apply to ships assigned an additional mark **FISHING VESSEL** or **FISHING CUTTER**, affixed to the symbol of class.

In addition the fishing vessels shall fulfil the provisions of *Council Directive 97/70/EC* of 11 December 1997 of European Communities, as amended by *Commission Directive 2002/35/EC* of 25 April 2002.

3.7.2 The stability of fishing vessels shall be calculated for the following loading conditions:

- .1 departure for the fishing grounds with full stores;
- .2 departure from the fishing grounds with full catch in holds or/and on deck (where provision for deck catch cargo has been made);
- .3 arrival at home port with full catch and 10% stores;
- .4 arrival at home port with 20% of full catch in holds or/and on deck (where provision for deck catch cargo has been made), with 70% of ice and salt rating and 10% stores;
- .5 on the fishing grounds according to 3.7.6.

3.7.3 The amount of full catch (in tonnes) shall be determined, depending on the ship type, capacity of cargo holds and the characteristics of the ship stability and buoyancy. It shall correspond to the permissible draught, accepted by PRS and it shall be clearly indicated in both stability calculations and stability booklet.

3.7.4 For net fishing vessels, allowance shall be made for wet fishing nets on deck in loading conditions specified in 3.7.2.2, 3.7.2.3 and 3.7.2.4.

3.7.5 The corrected metacentric height for fishing vessels shall not be less than 0.35 m; for ships with superstructure extending over the whole length of the ship or ships of 70 m in length L and upwards, the value of the metacentric height, upon PRS agreement, may be decreased, but in no case to the value lower than 0.15 m; the required value of the metacentric height 0.35 m shall not be decreased for loading condition given in 3.7.2.5 (on fishing grounds).

3.7.6 Fishing vessel shall fulfil weather criterion during fishing in the following loading condition: a vessel with no catch in holds, the catch and wet nets stowed on deck, 25% stores and full amount of ice and salt, the hatches of holds open. For vessels where nets and catch are hauled in with the help of cargo booms, account shall also be taken of the hoisted cargo of a mass equal to the rated hoisting capacity of the boom. The mass of catch allowed to be stowed on deck shall be specified in stability booklet.

3.7.7 When calculating weather criterion for a loading condition specified in 3.7.6, the following values shall be taken: the angle of roll equal to 10°; the angle of flooding equal to the open cargo hatch angle of flooding; the wind pressure for fishing grounds of unrestricted service ships shall be as that for ships of restricted service **I**, for ships of restricted service **I** – as that for ships of restricted service **II**, for ships of restricted service **II** – as that for such ships, but reduced by 30% (the required values of the wind pressures shall be taken from Table 2.2.1.5).

3.7.8 If the curve of static stability for a ship in loading condition, in accordance with 3.7.6, cuts short at the angle of flooding, it need not fulfil the requirements of 2.1.3 or 2.2.2, whichever applicable.

3.7.9 Fishing vessels engaged in the catch processing and having on board more than 12 members of the crew involved in the catch processing only shall fulfil the requirements of 3.1.3 to 3.1.6 and 3.1.8 to 3.1.10 in all loading conditions. In the stability calculations, the above-mentioned crew members shall be treated as passengers.

3.7.10 For ships of the length L up to 35 m, intended for restricted service, PRS may reduce the requirements for stability criteria (except the maximum lever of static stability), but by not more than 10%.

3.8 Tugs

3.8.1 The requirements of the present sub-chapter apply to ships assigned an additional mark **TUG**, affixed to the symbol of class. Compliance with the requirements, specified in 3.8.3 or 3.8.4, is confirmed by an appropriate entry made in Appendix to Certificate of Class.

3.8.2 General Requirements

3.8.2.1 The stability of tugs shall be calculated for the following loading conditions:

- .1 ship with full stores;
- .2 ship with 10% stores;

and additionally for tugs provided with cargo holds:

- .3 ship with full cargo in holds and with full stores;
- .4 ship with full cargo in holds and with 10% stores.

3.8.2.2 In addition to compliance with the requirements of Chapter 2, tugs shall have sufficient dynamic stability to withstand the heeling effect of an assumed jerk of the towing line, i.e. the angle of dynamic heel Θ_{dh} due to the assumed jerk of the towing line shall not exceed the angles specified in 3.8.3.1 and 3.8.4.1.

3.8.3 Tugs Intended to Perform Harbour Operations

3.8.3.1 The angle of dynamic heel shall not be greater than the flooding or capsizing angle, whichever is lesser.

The tug meets this requirement if the following condition is satisfied:

$$K_1 = \sqrt{\frac{l_{dk}}{l_{dw}}} \geq 1.00 \quad (3.8.3.1)$$

where:

- l_{dk} – the lever of dynamic stability at the angle of heel equal to the flooding angle (see 3.8.3.3) or capsizing angle Θ_k , determined without allowance for rolling, whichever is the lesser, [m];
- l_{dw} – the dynamic heeling lever characterizing the assumed jerk effect of the towing line (see 3.8.3.2), [m].

3.8.3.2 The dynamic heeling lever l_{dw} shall be calculated from the formula:

$$l_{dw} = l_v \left(1 + 2 \frac{T}{B} \right) \frac{b^2}{(1 + c^2)(1 + c^2 + b^2)} \quad [\text{m}] \quad (3.8.3.2-1)$$

where:

T – mean draught in the given loading condition, [m];

B – breadth of the tug, [m];

c – “dynamic” abscissa of the towing hook suspension point, to be determined from the formula:

$$c = 4.55 \frac{X_H}{L_0} \quad (3.8.3.2-2)$$

X_H – distance between the towing hook suspension and the ship centre of mass, measured in horizontal plane, [m];

L_0 – design length of the ship, [m];

b – “dynamic” ordinate of the towing hook suspension point, to be determined from the formula, [m]:

$$b = \frac{\frac{Z_H}{e} - a}{B} \quad (3.8.3.2-3)$$

Z_H – vertical coordinate of the towing hook suspension point in relation to the base plane, [m];

$$a = \frac{0.2 + 0.3 \left(\frac{2T}{B} \right)^2 + \frac{KG_0}{B}}{1 + 2 \frac{T}{B}} \quad (3.8.3.2-4)$$

$$e = 0.145 + 0.2 \frac{KG_0}{B} + 0.06 \frac{B}{2T} \quad (3.8.3.2-5)$$

KG_0 – vertical coordinate of the ship centre of mass above the base plane, [m];

l_v – vertical coordinate in relation to the base plane of the hydraulic pressure load point corresponding to the assumed top velocity v_R [m], determined from the formula:

$$l_v = \frac{v_R^2}{2g} \quad (3.8.3.2-6)$$

v_R – top velocity of the towing line transverse jerk, taken, depending on power P , from Table 3.8.3.2; top velocity v_R for the intermediate values of the engine power shall be determined by linear interpolation.

Table 3.8.3.2
Values of v_R

P [kW]	0÷150	300	450	600	750	900	1050	1200	1350	1500
v_R [m/s]	1.30	1.33	1.37	1.43	1.55	1.70	1.88	2.08	2.29	2.50

3.8.3.3 When calculating the stability of tugs for the towing line jerk effect, the angle of flooding shall be determined assuming that all doors leading to the engine and boiler casing and to the upper deck superstructure, as well as the doors of all companionways to the spaces below the upper deck, are open, irrespective of the doors design.

3.8.3.4 When calculating the stability of tugs for the towing line jerk effect, no account shall be taken of icing and the effect of free surfaces of liquids in tanks.

3.8.3.5 Where the tug is provided with special appliances for shifting the towing hook downwards or abaft, with the towing line athwartships, PRS may consider the assumption of X_H and Z_H values other than those specified in 3.8.3.2.

3.8.4 Tugs Intended for Ocean Towing

3.8.4.1 The angle of heel due to the towing line jerk under rolling shall not exceed the angle corresponding to the maximum of the static stability curve or the angle of flooding, whichever is lesser.

The tug satisfies this condition if the following requirement is met:

$$K_2 = \sqrt{\frac{l_{dm}}{l_{dw}}} - \Delta K \geq 1.0 \quad (3.8.4.1-1)$$

where:

l_{dm} – lever of dynamic stability at an angle of heel corresponding to the maximum of the static stability curve or the angle of flooding, whichever is the lesser, [m];

l_{dw} – dynamic heeling lever calculated in accordance with 3.8.3.2, [m]; l_v shall be taken equal to 0.200 m.

The value of ΔK accounts for the effect of rolling on the resultant angle of heel; it shall be determined from the formula:

$$\Delta K = 0.03 \Theta_a \left[\frac{1+c^2}{b} - \frac{1}{e} \left(a - \frac{KG}{B} \right) \right] \sqrt{\frac{GM_0}{1+2\frac{T}{B}}} \quad (3.8.4.1-2)$$

GM_0 – metacentric height, in the given condition, without the correction for free surface effect, [m];

Θ_a – angle of roll, determined in accordance with 2.2.1.7, [degrees].

The values c , b , e and a shall be calculated in accordance with 3.8.3.2.

3.8.4.2 When calculating the stability of tugs intended for ocean towing, it shall be taken into account that:

- .1 the requirement of 3.8.3.5 applies;
- .2 for the curve of static stability with two maxima or an extended horizontal region (see 3.8.4.1), the value of the angle at the first maximum or that corresponding to the middle of the horizontal region shall be taken;
- .3 stability for the towing line jerk effect shall be calculated without taking into account the effect of free surfaces of liquids in tanks.

3.8.4.3 When calculating the stability of tugs for compliance with the requirements of Chapter 2 and the present sub-chapter, the following icing rates shall be taken:

- .1 for tugs specially designed for salvage operations – twice that specified in 1.6.12;
- .2 for other tugs – in accordance with 1.6.12.

3.8.4.4 Where the tug intended for ocean towing operations may perform also harbour towing, the necessity to comply, by such a tug, with the requirements of 3.8.3 is subject to special consideration by PRS.

3.9 Supply Vessels

3.9.1 The requirements of the present sub-chapter apply to ships with the length L from 24 to 100 m, assigned an additional mark **SUPPLY VESSEL**, affixed to the symbol of class. The stability of ships of more than 100 m in length L is subject to special consideration by PRS.

3.9.2 Stability characteristics shall be calculated taking into account a trim due to heel.

3.9.3 In addition to loading conditions, specified in 1.6.9.2, the following loading conditions shall be calculated:

- .1 ship with full stores and full deck cargo with the greatest assumed stowage factor, at the most unfavourable location of the remaining part of the cargo (where tubes are carried on deck, it shall be assumed that they are filled with water);
- .2 ship in the same loading condition as in.1, but with 10% stores.

3.9.4 The volume V_a of the water trapped in tubes carried on deck shall be determined from formula 3.9.4, depending on the total volume V_r of the tube and the ratio of the freeboard f amidships to the ship length L_0 :

$$\begin{aligned} V_a &= 0.3 V_r && \text{for } \frac{f}{L_0} \leq 0.015 \\ V_a &= \left(0.5 - 13.3 \frac{f}{L_0} \right) V_r && \text{for } 0.015 < \frac{f}{L_0} < 0.03 \\ V_a &= 0.1 V_r && \text{for } \frac{f}{L_0} \geq 0.03 \end{aligned} \quad (3.9.4)$$

The volume V_r shall be taken as the sum of the inner volumes of tubes and the volume of the space between them.

If plugs have been applied in the tubes or if the tube pile height is greater than 0.4 of the ship draught, a decrease of the design amount of water trapped in tubes will be specially considered by PRS.

3.9.5 Stability of supply ships shall be in accordance with the requirements specified in sub-chapter 2.4 of Part B of the *Intact Stability Code – 2008*.

3.9.6 When calculating icing, the upper surface of cargo shall be treated as a deck and the lateral projection of the cargo over the bulwark – as a part of the design windage area. The mass of ice per square metre shall be taken in accordance with 1.6.12.

3.9.7 The design icing of the tube pile shall be taken as the mass of ice contained in the inner volume of the tubes and in the space between the tubes.

If special means preventing icing have been applied, the design icing of the tube pile will be specially considered by PRS. PRS may decrease the design icing requirements where this can be justified.

3.9.8 In each operating condition, the freeboard measured at the after perpendicular shall not be less than $0.005L$.

3.9.9 The maximum permissible mass of deck cargo, location of its centre of mass and the windage area, for each loading condition, shall be specified in *Stability Booklet*.

3.9.10 Supply ships intended to perform also towing operations shall fulfil the requirements specified in 3.8.

3.9.11 Ships intended also for operations connected with hoisting the anchor of a drilling unit shall fulfil the requirements of 4.1.8.1.1 and 4.1.8.1.4; the wind heeling moment M_w and the angle of roll Θ_a shall be determined according to a method approved by PRS.

3.10 Ships Intended for Carriage of Dangerous Bulk Cargoes

3.10.1 The requirements of the present sub-chapter apply to ships intended for the carriage of bulk cargoes liable to shift. Compliance with these requirements is confirmed with an appropriate entry made in Appendix to Certificate of Class.

3.10.2 Ships intended for the carriage of bulk cargoes covered by the *International Code for the Safe Carriage of Grain in Bulk* or the *Code of Safe Practice for Solid Bulk Cargoes* shall be provided with loading plans.

3.10.3 Loading plan of grain shall contain:

- .1** general characteristics of the ship and the detailed data necessary at loading the grain;
- .2** plan of grain distribution, taking into account the stowage factor $1.25 \div 2.12 \text{ m}^3/\text{t}$, the quantity of grain to be loaded and recommendations concerning preparation of the ship for loading and recommendations for loading operations;

- .3 *Stability Booklet* containing data on the ship stability at the beginning and at the end of the voyage, in loading conditions in accordance with the plan of grain distribution; *Stability Booklet* shall contain also instructions and the necessary materials enabling to determine and assess, in a simple and quick way, compliance with stability requirements in loading conditions other than those specified in the grain distribution plan;
- .4 documentation of arrangements preventing the shifting of grain (where provided); the documentation shall include characteristics and dimensions as determined by the applicable requirements.

3.10.4 Loading plan of bulk cargoes (other than grain) shall contain:

- .1 general characteristics of the ship;
- .2 plan of bulk cargoes distribution, taking into account the stowage factor and the quantity of cargo; the distribution of cargoes shall be such that the permissible stresses determined for the structure are not exceeded;
- .3 *Stability Booklet* of the ship loaded with bulk cargo and recommendations for maintaining sufficient stability during the whole voyage;
- .4 information on general precaution with respect to the safety of the ship, cargo and crew.

3.11 High-speed craft

3.11.1 High-speed craft, defined as a craft capable of a maximum speed, in m/s equal to or exceeding $3.7D^{0.1667}$, constructed on or after 1 January 1996 but before 1 July 2002, to which Chapter X of the 1974 SOLAS Convention applies, shall fulfil stability requirements of the 1994 HSC Code (resolution MSC.36(63)). Any high-speed craft to which Chapter X of the SOLAS Convention applies, irrespective of its date of construction, which has undergone repairs, alterations or modifications of a major character; and a high-speed craft constructed on or after 1 July 2002, shall fulfil stability requirements of the 2000 HSC Code (resolution MSC.97(73)).

3.12 Chemical Tankers

3.12.1 The requirements specified in this sub-chapter apply to ships to be assigned additional mark CHEMICAL TANKER in the symbol of class.

3.12.2 Chemical tankers shall fulfil the stability requirements specified in Chapter 2 of the *International Code for the Construction and Equipment of Ships Carrying Dangerous Chemicals in Bulk (IBC Code)*, as amended and Unified Interpretation by IACS UI CC7.

3.12.3 Chemical tankers constructed after 1 January 2016 shall be fitted with a stability instrument capable of verifying compliance with the intact and damage stability requirements approved by the Administration.

3.12.4 Existing chemical tankers constructed before 1 January 2016 shall fulfil the requirements specified in 3.12.3 at the first scheduled class renewal survey of the ship after 1 January 2016, however not later than 1 January 2021.

3.13 Gas Tankers

3.13.1 The requirements of this sub-chapter apply to ships to be assigned the additional mark: LIQUEFIED GAS TANKER in the symbol of class.

3.13.2 Gas tankers shall fulfil the stability requirements specified in Chapter II of the *Annex to International Code for Construction and Equipment of Ships Carrying Liquefied Gases in Bulk (IGC Code)* as amended.

3.13.3 All gas tankers shall have been fitted – at the first scheduled class renewal survey of the ship after 1 July 2016, however not later than 1 July 2021 – with a stability instrument capable of verifying compliance with the intact and damage stability requirements approved by the Administration.

3.13.4 Stability instrument fitted on board the ship before 1 July 2016 need not be replaced provided it is capable of verifying compliance with intact and damage stability to the satisfaction of the Administration.

3.14 Ships intended to operate in polar waters

3.14.1 Ships operating in areas of polar waters shall fulfil requirements specified in Chapter 4 of the *International Code for Ships Operating in Polar Waters (Polar Code)* (resolution MSC.385(94)).

4 STABILITY – REQUIREMENTS FOR TECHNICAL FLOATING UNITS

4.1 Floating Cranes

4.1.1 Application

The requirements of the present sub-chapter apply to ships assigned an additional mark **FLOATING CRANE**, affixed to the symbol of class.

4.1.2 Loading Conditions

4.1.2.1 The stability of a floating crane in working condition shall be calculated for the following loading conditions:

- .1** with full load on the hook at maximum load torque:
 - with full cargo and full stores,
 - with full cargo and 10% stores,
 - without cargo and with full stores,
 - without cargo and with 10% stores;
- .2** without load on the hook, with the highest position of the jib:
 - with full cargo and full stores,
 - with full cargo and 10% stores,
 - without cargo and with full stores,
 - without cargo and with 10% stores;
- .3** with the load broken off the hook.

The position of the slewing crane jib shall be assumed perpendicular to the centre plane of the ship.

In the case of a crane with non-swinging jib intended for operation in longitudinal plane, the unsymmetrical loads on the hooks, if allowed by crane design, shall be taken into account.

The design position of the centre of mass hoisted on the hook shall be assumed at the point of suspension to the jib.

For a ship with the load broken off the hook, the stability shall be calculated for the most unfavourable loading condition as regards stability, with the load on the hook, taking into account the possibility of unsymmetrical distribution of cargo on deck.

4.1.2.2 During passages, the stability shall be calculated with the jib in the “stowed for sea” position, for the following loading conditions:

- .1** with full cargo and full stores;
- .2** with full cargo and 10% stores;
- .3** without cargo and with full stores;
- .4** without cargo and with 10% stores.

4.1.2.3 Stability in non-working condition shall be calculated with icing, for the most unfavourable loading condition as regards stability, specified in 4.1.2.1.2.

4.1.3 Stability Booklet

4.1.3.1 *Stability Booklet* shall contain data on the ship stability in working conditions and in operation readiness (working and non-working conditions), as well as in cases of passages from one port to another, indicating measures necessary to ensure sufficient stability. Restrictions as to area of navigation shall be specified separately for working and passage conditions.

4.1.3.2 *Stability Booklet* shall contain data on stability at various extensions of the boom and different loads on the hook.

4.1.4 Calculation of Stability Characteristics

4.1.4.1 When calculating the stability characteristics, the operational trim may be taken into account.

4.1.4.2 When calculating the free surface effect, the heeling moment ΔM_{15} shall be taken equal to the moment due to liquid overflow at the ship heel of 15° . The heeling moment shall be calculated from the formula:

$$\Delta M_{15} = 0.0216 \rho v \frac{b^2}{h} \sqrt{\delta} \quad [\text{tm}] \quad (4.1.4.2)$$

where:

- v – tank total capacity, [m³];
- b – tank maximum breadth, [m];
- ρ – density of liquid in the tank, [t/m³];
- δ – tank block coefficient; $\delta = v / b h$;
- h – tank maximum height, [m].

4.1.4.3 Tanks complying with the following condition shall not be taken for calculations of the free surface effect:

$$\Delta M_{15} \leq 0.02 D_{\min} \quad (4.1.4.3)$$

D_{\min} – see 1.6.7.11.

4.1.4.4 The sum of heeling moments due to liquid overflow, not included in the calculations, shall not be greater than $0.05 D_{\min}$.

4.1.5 Calculation of Windage Area

4.1.5.1 The design windage area F_{zi} shall be taken as follows:

- 1 for continuous-walled structures – the projected area limited by the outline of the structure, machinery, gear, etc.;
- 2 for lattice type structures – the projected lateral area limited by the outline of the structure with apertures between girders deducted;
- 3 for structures with several beams equal in height, located one after another (Fig. 4.1.5.1):
 - the projected lateral area of the fore beam if the beam spacing is less than the fore beam height,
 - the total projected lateral area of the fore beam plus 50% of the projected lateral areas of subsequent beams if the beam spacing is equal to or greater than the fore beam height, but less than the double height of the fore beam;
 - the sum of projected lateral areas of all beams if the beam spacing is equal to or greater than the beam double height.

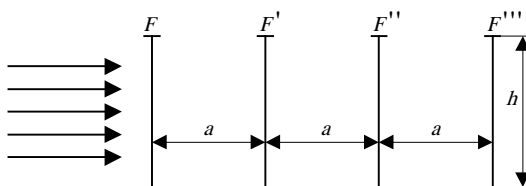

Fig. 4.1.5.1

$$\begin{aligned} \text{at } a < h & \quad F_{zi} = F = F' = F'' = F''' \\ \text{at } h \leq a < 2h & \quad F_{zi} = F + 0.5(F' + F'' + F''') \\ \text{at } a \geq 2h & \quad F_{zi} = F + F' + F'' + F''' \end{aligned}$$

- 4 In the case of beams not equal in height or not equally spaced, pairs of beams shall be sequentially analyzed, taking the fore beam height as h and the area of the higher beam as F .

4.1.5.2 The design arm of wind pressure Z shall be determined from the formula:

$$Z = \frac{\sum k_i n_i F_{zi} z_i}{\sum k_i n_i F_{zi}} \quad [\text{m}] \quad (4.1.5.2)$$

- z_i – height above waterline of the centres of component areas F_{zi} [m];
 k_i – value of the aerodynamic flow coefficient shall be taken from Table 4.1.5.2;
 n_i – zone coefficient, see 4.1.5.3.

Table 4.1.5.2
Aerodynamic flow coefficient k_i

Components of windage area	k_i	
Trusses and continuous beams	1.4	
Above-water part of the hull, box structures with smooth external surfaces, rectangular cabins, deck machinery, small objects on deck, counterbalances	1.2	
Tubular structures (depending on the product of the design wind pressure q_w [Pa] and the square of the tube diameter d_r [m])	for $q_w d_r^2 \leq 10$ N	1.2
	for $q_w d_r^2 \geq 10$ N	0.7
Cargo ropes (depending on diameter)	for $d \leq 20$ mm	1.2
	for $d > 20$ mm	1.0
Cargo	1.2	

Notes:

- For intermediate values of $q_w d_r^2$ – the value of coefficient k_i shall be determined by linear interpolation.
- The values of k_i – for components of structures other than those specified in Table 4.1.5.2 – will be specially considered by PRS in each particular case.
- In well-justified cases, PRS may give consent to other values of the coefficient k_i .

4.1.5.3 The value of zone coefficient n_i accounting for the variation of the wind pressure in dependence on the height of the centre of the windage area above the waterline shall be taken in accordance with Table 4.1.5.3.

Table 4.1.5.3
Zone coefficient n_i

Height above waterline (zone limits) [m]		n_i
from	to	
	< 10	1.00
10	< 20	1.25
20	< 30	1.40
30	< 40	1.55
40	< 50	1.69
50	< 60	1.75
60	< 70	1.84
70	< 80	1.94
80	< 90	2.02
90	< 100	2.10

4.1.5.4 It is recommended that for every loading condition of a floating crane, the windage area of discontinuous structures, ropes, rigging of masts and other small objects should be taken into account by increasing the total windage area of continuous structures (with due regard to coefficients k_i and n_i) and the static moment of that area.

For floating cranes not subjected to icing, the windage area shall be increased by 2% and the static moment of that area – by 5%.

For floating cranes subjected to icing, the windage area and the static moment shall be increased by 4% and 10% or by 3% and 7.5%, respectively – depending on the rate of icing, according to 1.6.12.3, 1.6.12.4 and 1.6.12.5, as appropriate.

4.1.5.5 The design windage area of cargo shall be determined in accordance with its actual outline – with due regard to the flow coefficient and the maximum hoisting height, i.e. analogous to 4.1.5.1, taking into account the requirements of 4.1.5.2 and 4.1.5.3.

The centre of the windage area of the hoisted cargo shall be assumed at the point of cargo suspension to the jib. If the actual data are not available, the design windage area of cargo shall be assumed in accordance with Table 4.1.5.5.

Table 4.1.5.5
Windage area of cargo

Mass of cargo [t]	Design windage area of cargo $k_i F_{zi}$ [m ²]
10	12
20	19
32	24
40	26
50	30
63	34
80	38
100	43
125	48
140	54
160	58
180	60
200	64
225	67
250	72
280	75
320	85
400	96
500	108
630	127
710	135
800	142
900	150
1000	157

4.1.6 Angle of Roll Calculation

4.1.6.1 The angle of roll shall be calculated from the formula:

$$\Theta_a = X_{1,2} X_3 Y + \Delta\Theta \quad [\text{degrees}] \quad (4.1.6.1-1)$$

$X_{1,2}, X_3$, – factors;

Y – coefficient [degrees];

$\Delta\Theta$ – correction for the height of the centre of mass of a floating crane above waterline [degrees].

The value of factor $X_{1,2}$ shall be taken in accordance with Table 4.1.6.1-1.

The value of factor $X_{1,2}$ for $0.25 < \frac{h_{3\%}}{\sqrt{\delta BT}} < 0.50$ shall be determined by linear interpolation. The height

of wave with 3% probability of exceeding ($h_{3\%}$) shall be taken in accordance with the sea state at which operation of a floating crane (for working condition) is allowable or depending on navigation area – in accordance with Table 4.1.11.2 (for passages).

The value of factor X_3 shall be determined in accordance with Fig. 4.1.6.1.

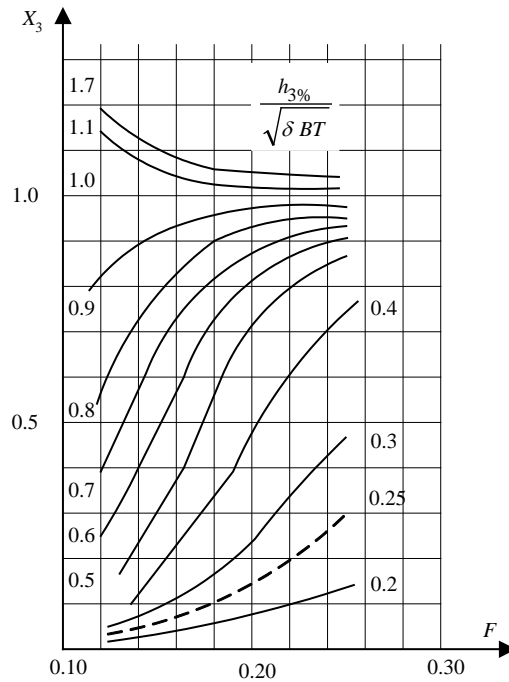

Fig. 4.1.6.1

The value of coefficient Y shall be taken in accordance with Table 4.1.6.1-2.

Table 4.1.6.1-1
Factor $X_{1,2}$

The value of $\frac{B}{\delta T}$		9.0	9.5	10.0	10.5	11.0	11.5	12.0	13.0	14.0
The value of $X_{1,2}$	$\frac{h_{3\%}}{\sqrt{\delta BT}} \geq 0.50$	1.48	1.38	1.29	1.23	1.17	1.13	1.09	1.03	0.99
	$\frac{h_{3\%}}{\sqrt{\delta BT}} \leq 0.25$	1.98	1.83	1.68	1.54	1.42	1.31	1.22	1.08	0.97

Table 4.1.6.1-2
Coefficient Y

The value of F	0.14	0.15	0.16	0.17	0.18	0.19	0.20	0.21	0.22	0.23	0.24
Y [degrees]	34.2	32.4	30.1	27.3	24.8	22.6	20.4	18.7	17.0	15.5	14.3

The value of F shall be calculated from the formula:

$$F = n \frac{\sqrt{GM_0}}{B} \sqrt[4]{\delta BT} \tag{4.1.6.1-2}$$

where:

n – coefficient, equal to:

$n = 0.414$ – for a floating crane with the jib parallel to the centre plane,

$n = 0.331$ – for a floating crane with the jib perpendicular to the centre plane;

GM_0 – metacentric height (without correction for the effect of free surfaces of liquids), [m];

δ – see 4.1.4.2;

B, T – see 1.3.

Correction $\Delta\theta$ shall be calculated from the formula:

$$\Delta\theta = 68 \frac{h_{3\%} F}{\sqrt{\delta BT}} \left[\frac{KG - T}{\sqrt{\delta BT}} - 0.41 \left(\frac{B}{\sqrt{\delta BT}} - 2.1 \right) \right] \quad [\text{degrees}] \quad (4.1.6.1-3)$$

where:

KG – corrected (for the effect of free surfaces of liquids) height of the ship centre of mass, [m].

4.1.6.2 If, during a passage, the angle of roll, calculated in accordance with 4.1.6.1-1, is greater than the angle θ_d at which the deck immerses or greater than the angle θ_b at which the middle of the bilge in the midship portion of the ship comes out of water, the design angle of roll θ_{av} , to be taken for calculations, shall be determined from the following formulae:

.1 when $\theta_d < \theta_a \leq \theta_b$

$$\theta_{av} = \frac{\theta_d + 5\theta_a}{6} \quad [\text{degrees}] \quad (4.1.6.2-1)$$

.2 when $\theta_b < \theta_a \leq \theta_d$

$$\theta_{av} = \frac{\theta_b + 5\theta_a}{6} \quad [\text{degrees}] \quad (4.1.6.2-2)$$

.3 when $\theta_a > \theta_b$ and $\theta_a > \theta_d$

$$\theta_{av} = \frac{\theta_d + \theta_b + 4\theta_a}{6} \quad [\text{degrees}] \quad (4.1.6.2-3)$$

4.1.7 Icing

At the level of 10 m or more above the waterline, the mass of ice per square metre shall be assumed to be half those specified in 1.6.12.3 to 1.6.12.5; the windage area and its centre shall be determined:

- .1** for such loading condition among those mentioned in 1.4.2.2 which results in the least draught;
- .2** for a loading condition chosen for calculation of stability in accordance with 4.1.2.3.

4.1.8 Stability of a Floating Crane in Working Condition

4.1.8.1 The stability of a floating crane in working condition is considered to be sufficient if:

- .1** the angle of heel caused by a combined effect of the heeling moment (due to the load on the hook or the counterbalance in the case of no load, etc.), the static effect of wind pressure and rolling is not greater than the angle at which the operation of the crane is safe (see 4.1.2.8), the angle at which the deck immerses and the angle at which the middle of the bilge in the midship portion of the ship comes out of water. Moreover, the value of that angle in no case shall exceed:
 - 8° for floating cranes intended to operate in the rough sea;
 - 6° for floating cranes not intended to operate in the rough sea;
 and the vertical distance of openings, which determine the flooding angle in working condition, from the waterplane shall not be less than 600 mm.
 For floating cranes intended to operate at greater angle of heel, the permissible value of the angle is subject to special consideration by PRS in each particular case.
- .2** the value of the maximum static stability righting lever at an angle of heel not less than 14° is not less than 1.0 m and the range of positive static stability is not less than 25°;
- .3** the capsizing moment M_{kr} , calculated for the combined effect of the cargo breaking off and rolling, is at least twice the heeling moment due to the wind pressure M_w ;
- .4** the angle of dynamic heel due to a combined effect of the cargo breaking off, the wind pressure and rolling is at least by 1° smaller than the flooding angle of the crane in working condition.

4.1.8.2 The angle of heel at which the operation of the crane is safe shall be assumed, taking into account technical conditions determined during the crane acceptance tests.

4.1.8.3 The angle of heel caused by the combined effect of the heeling moment (due to the load on hook) Θ_b , the static effect of the wind pressure Θ_s and rolling Θ_a shall be calculated from the formula:

$$\Theta_p = \Theta_0 + \Theta_s + \Theta_a \quad (4.1.8.3-1)$$

where:

$$\Theta_0 = 57.3 \frac{y_G}{GM} \quad [\text{degrees}] \quad (4.1.8.3-2)$$

y_G – transverse shift of the ship centre of mass, [m];

GM – corrected (for the effect of free surfaces of liquids) metacentric height, [m];

$$\Theta_s = \frac{57.3 M_w 10^{-3}}{9.81 DGM} \quad [\text{degrees}] \quad (4.1.8.3-3)$$

M_w – heeling moment due to wind pressure for a floating crane intended to operate without heel; it shall be calculated from the formula:

$$M_w = 9.81 \cdot 15 \left(Z + f_1 \sqrt{\delta BT} \right) \sum k_i n_i F_{zi} \quad [\text{Nm}] \quad (4.1.8.3-4)$$

f_1 – factor; to be taken in accordance with Table 4.1.8.3.

F_{zi} , k_i , n_i , Z – see 4.1.5.2.

Θ_a – to be calculated in accordance with 4.1.6.1;

$\Theta_a = 0$ for floating cranes not intended to operate in the rough sea.

Angles Θ_b , Θ_s and Θ_a shall be assumed to have the direction of the heel.

Table 4.1.8.3
Factor f_1

$\frac{B}{\sqrt{\delta BT}}$	Θ_b [degrees]					
	0	2	4	6	8	10
2.0	0.43	0.44	0.42	0.36	0.27	0.18
2.2	0.64	0.67	0.62	0.47	0.33	0.22
2.4	0.88	0.96	0.82	0.58	0.39	0.26
2.6	1.18	1.28	1.02	0.69	0.46	0.31
2.8	1.53	1.68	1.22	0.80	0.52	0.35
3.0	1.95	2.06	1.43	0.91	0.58	0.39
3.2	2.43	2.48	1.64	1.02	0.64	0.43
3.4	2.99	2.89	1.87	1.13	0.71	0.48
3.6	3.62	3.30	2.09	1.24	0.77	0.52
3.8	4.32	3.71	2.33	1.35	0.83	0.56

Intermediate values of f_1 shall be determined by linear interpolation.

4.1.8.4 In well-justified cases, it is allowed – upon PRS agreement – to impose additional weather restrictions on performing lifting operations. In such case, when calculating stability, the design wind pressure and design wave height shall be taken in accordance with Table 4.1.8.4 – considering the imposed weather restrictions.

Table 4.1.8.4
Wind pressure and wave height

Specified wind restriction [degrees]	Design wind pressure q_w [Pa]	Defined wave restriction, sea state	Design wave height $h_{3\%}$ [m]
1	10	–	–
2	20	1	0.25
3	30	2	0.75
4	50	3	1.25
5	90	4	2.00

4.1.8.5 The angle of heel of a floating crane before the load breaking off shall be taken equal to the sum of angles of heel due to the load on hook and unsymmetrical cargo distribution on deck Θ , as well as the angle of roll Θ_a , with the angle of heel due to static effect of the wind pressure Θ_s deducted. The recommended method of determining the capsizing moment and the angle of dynamic heel is given in *Publication No. 6/P – Stability*.

4.1.8.6 The heeling moment M_w may, subject to PRS consent in each particular case, be calculated taking into account the effect of mooring lines and chain cables.

4.1.8.7 Where the tests of floating crane are performed under the load exceeding the rated load, stability shall be calculated for this particular loading condition to prove that the condition is safe as regards stability during the tests.

4.1.9 Stability of a Floating Crane During Passage within the Assigned Navigation Area

4.1.9.1 The stability of a floating crane is considered to be sufficient if:

- .1 the value of the static stability righting lever at an angle of heel 15° is not less than 1.5 m and the range of positive static stability is not less than 45° ;
- .2 the capsizing moment M_{kr} , calculated with regard to rolling, is not less than the heeling moment M_w (determined in accordance with 4.1.9.2).

4.1.9.2 The heeling moment M_w shall be calculated from the formula:

$$M_w = 0.6q_w \left(Z + \frac{f_1}{2} \sqrt{\delta BT} \right) \sum k_i n_i F_{zi} \quad [\text{Nm}] \quad (4.1.9.2)$$

where:

q_w – design wind pressure, to be taken in accordance with Table 4.1.11.2;

f_1 – coefficient, to be taken in accordance with Table 4.1.8.3 for $\Theta_0 = 0^\circ$;

δ – see 4.1.4.2;

B, T – see 1.3;

F_{zi}, k_i, n_i, Z – see 4.1.5.2.

4.1.9.3 The recommended method of determining the capsizing moment is given in *Publication No. 6/P – Stability*.

4.1.9.4 The design wave height $h_{3\%}$ shall be taken in accordance with Table 4.1.11.2.

4.1.9.5 If a floating crane is intended to operate in a specified geographical region, the values of q_w and $h_{3\%}$, specific for such region, may be taken subject to agreement with PRS.

4.1.10 Stability of a Floating Crane in Non-working Condition

4.1.10.1 The stability of a floating crane is considered to be sufficient if, in the loading condition required in 4.1.2.3, the capsizing moment, calculated without allowance for rolling, is at least 1.5 times the heeling moment due to the static wind effect.

4.1.10.2 The heeling moment shall be calculated from formula 4.1.9.2 with $q_w = 1300$ Pa.

4.1.10.3 The recommended method of determining the capsizing moment is given in *Publication No. 6/P – Stability*.

4.1.11 Stability of a Floating Crane during Passage outside the Assigned Navigation Area

4.1.11.1 When a floating crane is to undertake a passage outside the assigned navigation area, a plan of such passage shall be prepared and submitted to PRS for approval.

4.1.11.2 Stability shall be calculated for loading conditions specified in 4.1.2.2 taking into account icing, having regard to preparations provided by the plan of passage (in this the possibility of partial or complete dismantling of the crane).

Table 4.1.11.2
Wind pressure and wave height

Navigation area of a floating crane passage	Design wind pressure q_w [Pa]	Design wave height $h_{3\%}$ [m]
Restricted I	1000	5.83
Restricted II	800	5.83
Restricted III	600	3.50

4.1.11.3 Stability is considered sufficient if it fulfils the requirements of 4.1.9 concerning the area of passage.

4.1.11.4 The design wind pressure and the design wave height shall be taken in accordance with Table 4.1.11.2, depending on the navigation area.

4.2 Dredging Fleet

4.2.1 Application

The requirements of the present sub-chapter apply to ships assigned an additional mark **DREDGER** or **HOPPER BARGE**, affixed to the symbol of class.

4.2.2 Working Conditions

4.2.2.1 Depending on the area of the ship operation and its designation, the following working zones are distinguished:

- .1 working zone 1 – coastal zone within 20 miles from the coast;
- .2 working zone 2 – zone covering the assigned area of the ship navigation, not belonging to the working zone 1.

4.2.2.2 *Stability Booklet* shall contain data on the ship stability both in operating conditions and in the cases of passages from one port to another, specifying measures necessary to ensure sufficient stability. Weather restrictions in operating conditions shall be specified with due regard paid to the requirements of 4.2.5.2.

4.2.3 Loading Conditions

4.2.3.1 Loading conditions for ships of dredging fleet during passages in the assigned area of navigation:

- .1 ship without spoil, with working appliances secured for sea and with full stores;
- .2 ship in the loading condition as specified in .1, but with 10% stores.

4.2.3.2 Loading conditions for hopper dredgers and hopper barges in working conditions:

- .1 ship with spoil in the hopper, with working appliances secured for sea and with full stores;
- .2 ship in the loading condition as specified in .1, but with 10% stores.

For hopper dredgers provided with grabs, the additional loading conditions at grab operating from one side shall be considered assuming the following:

- crane boom in the athwartships plane, the grab filled with spoil;
- maximum moment caused by the grab load;
- the highest position of the crane;
- initial heel.

These conditions shall be considered for a ship with full stores and with 10% stores, with and without spoil.

Notes:

1. The mass of spoil in the grab shall be taken equal to 1.6ν tonnes (ν – grab capacity [m^3]).
2. The quantity of spoil in the hopper and the position of the centre of mass shall be determined assuming that the hopper is filled with homogeneous spoil to the level of the upper discharge holes or to the upper coaming edge if the discharge holes are not provided, at the ship draught to the freeboard mark allowed during performing the dredging.

4.2.3.3 Loading conditions for bucket dredgers in working conditions:

- .1** ship with spoil in buckets, with the bucket ladder secured for sea and with full stores;
- .2** ship in the loading condition as in .1, but with 10% stores.

Notes:

1. It shall be assumed that the spoil is in buckets on the working side of chain (from the upper to the lower reel).
2. The mass of spoil in each bucket is assumed to be equal to 2ν tonnes (ν – the total capacity of bucket [m^3]).

4.2.3.4 Loading conditions for dredgers of types other than bucket dredgers, in working conditions:

- .1** ship with working appliances in the highest position possible under normal operation, with full stores;
- .2** ship in loading condition as in .1, but with 10% stores.

For dredgers provided with grab cranes, the additional loading conditions, in accordance with 4.2.3.2, shall be considered.

Notes:

1. It shall be assumed that, within the ship, the pipeline silting up soil is filled with spoil having density $1.3 \text{ [t/m}^3\text{]}$.
2. The mass of spoil in the grab is assumed to be equal to 1.6ν tonnes (ν – the grab capacity [m^3]).

4.2.4 Calculation of Cross Curves of Stability and Inclining Test

4.2.4.1 When calculating cross curves of stability, the deck manholes of void spaces may be considered as closed, irrespective of the coamings height, if they are provided with watertight covers.

4.2.4.2 For ships, the design of which does not ensure watertightness of hold, the inclining test may be performed with water in hold connecting freely with sea water.

4.2.5 Calculation of Stability in Working Conditions and during Passages within Assigned Area of Navigation

4.2.5.1 When calculating stability during passage within the assigned area of navigation, stability booklet shall contain conditions of passage, if provided (liquid ballast, range of dismantling the working appliances, place of bucket ladder suspension, the possibility of carrying the spoil in the hopper beyond the limits of 20-mile coastal zone, etc.). In an unrestricted area of navigation, the bucket dredgers may undertake passages only with the bucket chain removed.

4.2.5.2 When calculating the stability of ships in working conditions, the following shall be assumed:

- .1** in working zone 1:
wind pressure – for ships of unrestricted service – as for ships of restricted service I; for ships of restricted service I – as for ships of that area of navigation but reduced by 25%; for ships of other areas of navigation – as for restricted service II; the angle of roll – as for restricted areas of navigation;
- .2** in working zone 2:
wind pressure and the angle of roll – in accordance with the area of navigation.

4.2.5.3 The angle of roll of dredging fleet ships with no cut-outs in the hull, no bilge keel or bar keel shall be determined from formula 2.2.1.7, taking the values of Y in accordance with 2.2.1.7, the values of X_1 – in accordance with Table 4.2.5.3-1 and the values of X_2 – in accordance with 2.1.2.6-3.

For restricted service areas **I** and **II**, the angle of roll, calculated from formula 2.2.1.7, shall be multiplied by coefficient X_3 in accordance with Table 4.2.5.3-2.

Bilge keel or bar keel and the bilge shape shall be taken into account in accordance with the requirements of 2.2.1.7.

For hopper dredgers and hopper barges with recesses in the bottom to support the doors, coefficient X_1 shall be determined according to Table 4.2.5.3-1 for B/T multiplied by coefficient $\frac{V+V_w}{V}$,

where:

V – ship displacement, disregarding the volume of recesses, [m³];

V_w – volume of recesses, [m³].

Table 4.2.5.3-1
Coefficient X_1

Type of ship	B/T ratio	2.50	2.75	3.00	3.25	3.50	3.75	4.00	4.25	4.50	4.75	5.00	5.25	5.50
Dredgers without hoppers	X_1	1.08	1.06	1.04	1.02	1.00	0.99	0.98	0.96	0.94	0.91	0.90	0.90	0.90
Hopper dredgers and hopper barges	X_1	1.12	1.09	1.06	1.03	1.01	0.98	0.96	0.94	0.92	0.90	0.88	0.85	0.83

Table 4.2.5.3-2
Coefficient X_3

$\frac{\sqrt{GM_0}}{B}$	≤ 0.04	0.05	0.06	0.07	0.08	0.09	0.10	0.11	0.12
X_3	1.27	1.23	1.16	1.08	1.05	1.04	1.03	1.02	1.01
$\frac{\sqrt{GM_0}}{B}$	0.13	0.14	0.15	0.16	0.17	0.18	0.19	≥ 0.20	
X_3	1.00	1.00	1.01	1.03	1.05	1.07	1.10	1.13	

4.2.5.4 The stability of dredgers provided with grab cranes, in additional loading conditions (see 4.2.3.2), shall fulfil the requirements of 4.1.

4.2.5.5 For hopper dredgers and hopper barges in which the construction of bottom doors provides for the possibility of spoil discharge from one side, the stability, with regard to such case, shall be calculated for weather criterion only considering the requirements of 4.2.5.6 and 4.2.5.7 for the worst loading condition from among those specified in 4.2.3.2.1 and 4.2.3.2.2:

- .1 for the density of spoil in the hopper not less than 1.3 t/m³ – at the static angle of heel Θ_{BC} and the angle of roll 10°;
- .2 for the density of spoil in the hopper not less than 1.3 t/m³ – taking into account the dynamic feature of the spoil discharge – at the angle of roll equal to the sum of 10° plus the maximum angle of the ship roll Θ_{ap} with respect to the static angle of heel Θ_{BC} immediately after the discharge; the value of Θ_{ap} shall be determined from the formula:

$$\Theta_{ap} = 0.2 \Theta_{BC} \quad [\text{degrees}] \quad (4.2.5.5.2)$$

The recommended curve for determining the capsizing moment is given in *Publication No. 6/P – Stability*.

4.2.5.6 The value of the horizontal shifting of the ship centre of mass when discharging half the spoil from one side from a fully loaded hopper shall be determined from the formula:

$$y_G = \frac{Py}{2D} \quad [\text{m}] \quad (4.2.5.6-1)$$

where:

P – total mass of spoil in the hopper, [t];

y – distance from the centre of mass of spoil, discharged from one side, to the centre plane, [m];

D – ship displacement after spoil discharge, to be calculated from the formula:

$$D = D_{\max} - \frac{P}{2} \quad [\text{t}] \quad (4.2.5.6-2)$$

D_{\max} – ship displacement prior to spoil discharge, [t].

4.2.5.7 The curves of static and dynamic stability shall be calculated from the formulae:

$$GZ_1 = GZ - y_G \cos \Theta \quad [\text{m}] \quad (4.2.5.7-1)$$

$$l_{d1} = l_d - y_G \sin \Theta \quad [\text{m-rad}] \quad (4.2.5.7-2)$$

where:

GZ and l_d – static and dynamic stability levers at the ship displacement D_{\max} , assuming that the ship centre of mass coincides with the centre plane.

4.2.5.8 When spoil is discharged by a conveyor, the stability of a dredger shall be calculated for the case of static action of the moment due to the mass of the conveyor (in the athwarship plane) filled with spoil, disregarding the wind and waves effects. The stability of the ship is considered to be sufficient if the maximum static angle of heel is not greater than the angle of flooding or the angle at which the freeboard becomes equal to 300 mm, whichever is the lesser.

4.2.6 The Effect of Liquid Cargoes

When calculating the effect of liquid cargoes on hopper dredgers and hopper barges stability, as specified in 1.6.7, it shall be assumed that:

- .1** the spoil with density of more than 1.3 t/m^3 is regarded as a solid, non-overflowing cargo; the levers of static and dynamic stability shall be calculated at the constant displacement and constant position of the centre of mass of spoil in the hopper;
- .2** the spoil with density of less than 1.3 t/m^3 is regarded as a liquid cargo; the levers of static and dynamic stability shall be calculated at variable displacement and variable position of the spoil centre of mass, having regard to the spoil flowing overboard and the decrease of the ship draught; where the ship is provided with a longitudinal bulkhead in the hopper precluding the cargo shifting, such cargo may be regarded as solid;
- .3** for a ship without spoil, the hopper is assumed to be in contact with sea water, i.e. the hopper doors and valves are open; the levers of static and dynamic stability shall be calculated for the constant displacement (as for a damaged ship).

4.2.7 The Effect of Dredging Gear Icing

When calculating the effect of icing on stability, the horizontal projection of dredging gear shall be added to the horizontal projection of decks (the centre plane projection is included in the windage area). The moment due to this additional ice load related to the base plane shall be determined by the height of the centre of mass of the projection of a dredging gear in working or voyage position on the centre plane.

4.2.8 Static Stability Curve

4.2.8.1 The static stability righting levers curve of hopper dredgers or hopper barges during passages within the assigned area of navigation and in working conditions shall fulfil the requirements of 2.1.3.

4.2.8.2 The static stability righting levers curve of bucket dredgers in loading conditions specified in 4.2.3, taking into account icing, shall fulfil the following requirements:

- .1** the range of positive righting levers of the curve Θ_v shall not be less than 50° ;
- .2** the value of the maximum righting lever of static stability GS_M at the angle Θ_m not less than 25° shall be:
 - not less than 0.25 m for the ship operation in working zone 1;
 - not less than 0.40 m during passages and for the ship operation in working zone 2.

4.2.8.3 For bucket dredgers with $B/H > 2.5$ ratio, the range of positive righting levers of static stability curve and the angle at which the maximum righting lever should occur may be reduced, as compared to those required in 4.2.8.2, by the following values:

- .1 the range of positive righting levers – by the value of angle $\Delta\Theta$, determined from the formula:

$$\Delta\Theta = 25^\circ \left(\frac{B}{H} - 2.5 \right) (K - 1) \quad [\text{degrees}] \quad (4.2.8.3)$$

where:

K – weather criterion coefficient, see 2.2.1.

For $B/H > 3.0$ or $K > 1.5$, the values of $B/H = 3.0$ and $K = 1.5$, respectively shall be taken.

The value of $\Delta\Theta$ shall be rounded off to the nearest whole number;

- .2 the angle at which the maximum righting lever should occur – by the value equal to half the angle $\Delta\Theta$.

For dredgers of unrestricted service, the values of angles Θ_v and Θ_m , required in 4.2.8.2, shall not be reduced.

4.3 Pontoons

4.3.1 Application

The requirements of the present sub-chapter apply to pontoons with a breadth/ depth ratio $B/H \geq 3$ and block coefficient $\delta > 0.9$, assigned additional mark **PONTOON**, affixed to the symbol of class.

4.3.2 Loading Conditions

4.3.2.1 The stability of pontoons shall be calculated for the following loading conditions:

- .1 fully loaded;
- .2 without cargo;
- .3 fully loaded, including the effect of icing.

When calculating stability of pontoons intended for the carriage of timber, account shall be taken of the requirements associated with the additional mark **TIMBER** – see 3.5.

4.3.2.2 When calculating stability of pontoons intended for the carriage of pipes, account shall be taken of the mass of water trapped in the pipes, in accordance with 3.9.4.

4.3.3 Icing

When calculating stability, icing shall be taken into account in accordance with 1.6.12; in the case of timber cargo – account shall be taken of the requirements specified in 3.5.6; in the case of pipes cargo – account shall be taken of the requirements specified in 3.9.6 and 3.9.7.

4.3.4 Stability Criteria

4.3.4.1 The stability of a pontoon is considered to be sufficient if:

- .1 the area under the static stability curve, calculated for the angle of heel Θ_m , is not less than 0.08 m-rad;
- .2 the static angle of heel caused by the heeling moment due to wind, determined in accordance with 4.3.4.2, is not greater than half the angle at which the deck immerses;
- .3 the range of static stability righting levers curve is:
 - for pontoons with the length $L_0 \leq 100$ m – not less than 20° ,
 - for pontoons with the length $L_0 > 150$ m – not less than 15° ,
 - for pontoons of intermediate lengths, the range of static stability is calculated by linear interpolation.

4.3.4.2 The heeling moment due to the effect of wind shall be calculated from the formula:

$$M_w = q_w \cdot z \cdot F_w \quad [\text{kNm}] \quad (4.3.4.2)$$

where:

q_w – wind pressure, [kPa]; $q_w = 0.54$ kPa shall be taken;

- F_w – windage area (in accordance with 1.6.6), [m²];
 z – distance from the centre of the windage area to half the draught, [m].

4.3.5 Stability Documentation

4.3.5.1 pontoons are not subject to the requirements of 1.4.1.1 and 1.4.1.2.

4.3.5.2 The following documentation shall be submitted to PRS for consideration:

- .1** body lines, hydrostatic curves, cross curves of stability;
- .2** calculations of wind heeling levers (with icing and without icing);
- .3** calculations of pontoon lightweight and the centre of mass coordinate, including the draught measurement report;
- .4** the assumed position of the vertical centre of pontoon lightweight, with justification;
- .5** *Stability Booklet* containing guidance for cargo loading and arrangement to allow the pontoon to fulfil stability requirements, as well as diagrams of static stability righting levers.

4.3.5.3 The documents, detailed in 4.3.5.2.1 to 4.3.5.2.4, shall be submitted for information; *Stability Booklet*, depending on the pontoon construction stage, is subject to acceptance or approval.

5 SUBDIVISION

5.1 Application

5.1.1 The requirements of the present Chapter apply to ships specified in sub-chapter 5.3.

5.1.2 The detailed scope of requirements is connected with an additional mark assigned to the given type of ship, affixed to the symbol of class.

5.1.3 Compliance with the requirements, set forth in the present Chapter, is confirmed by an appropriate additional mark, affixed to the symbol of class.

5.2 General Requirements

5.2.1 Subdivision

5.2.1.1 Ships shall be adequately divided into watertight compartments.

5.2.1.2 The ship division into watertight compartments is considered to be adequate if it fulfils the requirements for subdivision and damage stability or the required probability of the ship survival after flooding a compartment/compartments as a result of damage, specified in the present *Rules* for the particular type of ship.

5.2.2 Permeability

5.2.2.1 When determining subdivision, including the subdivision index, the permeability of compartments shall be taken in accordance with the requirements specified for the given type of ship.

5.2.2.2 In the case of detailed calculation of cargo spaces permeability (including refrigerated cargo spaces), the permeability of the cargo shall be taken equal to 0.60, while that of cargo in containers, trailers and vans – equal to 0.71.

5.2.2.3 In special cases, justified by the ship arrangement or nature of its service, PRS may require that other permeability values should be applied.

5.2.3 Calculation of Damage Stability Characteristics

5.2.3.1 The volume and free surfaces of water which can flood the ship compartments shall be calculated to the inner surface of the shell plating.

5.2.3.2 When plotting static stability curves for a damaged ship, enclosed superstructures, deckhouses, deck cargo, the angles of flooding through openings in the ship sides, decks, bulkheads of hull and superstructures, considered to be open, as well as correction for the effect of free surfaces of liquids shall be taken into account in the same way as it is shown in 1.6.7 and 1.6.10 for intact stability curves.

5.2.3.3 Superstructures and deckhouses which sustained damage shall be taken for calculations with adequate permeability only or shall be disregarded. Openings in such structures, leading to spaces which are not flooded, shall be considered as open at the relevant angles of heel only in the cases where they are not provided with weathertight closures.

5.2.3.4 When calculating the draught, heel and trim, as well as damage stability of a damaged ship, the changes in loading conditions of the ship shall be taken into account by substituting liquid cargo, in damaged tanks, by adequate amount of sea water.

5.2.3.5 Surface permeability values – the conventional numerical factors used in determining waterline areas, static moments and moments of inertia, changed due to cargo, machinery and equipment in way of damage waterline – shall be taken as equal to the volume permeabilities, determined in accordance with 5.2.2.

5.2.3.6 The time of the ship equalization after damage to attain the permissible angles of heel shall not exceed 10 minutes for passenger ships. For a non-passenger ship, the longest permissible time of equalization, determined according to the type of ship and its designation, is subject to PRS agreement in each particular case.

5.2.3.7 The arrangements for the ship equalization after damage shall be type-approved by PRS. It is recommended that they should be self-acting.

5.2.4 Stability and Subdivision Booklet

5.2.4.1 *Stability Booklet* for ships specified in 5.3, except those specified in 5.3.1, 5.3.2 and 5.3.4, shall be supplemented with *Subdivision Booklet* complying with the requirements of 5.2.4.2. For practical reasons, *Stability Booklet* and *Subdivision Booklet* may be separate documents.

5.2.4.2 Subdivision booklet shall contain requirements and guidance enabling the master to estimate the condition of the ship when its compartment/compartments are flooded and to undertake necessary measures to maintain the damaged ship afloat.

Subdivision Booklet shall contain the following:

- .1** information necessary to maintain such stability of a damaged ship which is sufficient to obtain, in the case of a compartment/compartments flooded, the required stability parameters for the most unfavourable loading condition – the basic information is KG_{\max}/GM_{\min} curve (except tankers);
- .2** instructions on loading and ballasting the ship, with recommendations on distributing the cargo, stores and ballast so as to fulfil the requirements for the ship subdivision, trim and stability;
- .3** results of calculations of symmetrical and unsymmetrical flooding, containing the data on:
 - the initial and damage draught,
 - heel,
 - trim,
 - the location of the ship centre of mass, both before and after equalization or improving the ship stability,
 - the recommended measures for improving the ship stability, indicating the period of time required;
- .4** static stability curves of a damaged ship in the selected typical loading conditions (most unfavourable as regards subdivision) for all compartments or a group of adjacent compartments;
- .5** data on structural measures to ensure the ship subdivision/survival capability, instructions concerning the operation of cross-flooding arrangements and other emergency appliances,
- .6** recommendations, specific for the given ship, for proceedings under normal service conditions, as well as instructions for proceedings in the case of ship damage specifying the activities related to the ship survival.

5.2.4.3 *Stability Booklet* for ships, specified in 5.3.1, 5.3.2 and 5.3.4, shall be supplemented with the following data:

- .1** diagram of the permissible value of the vertical coordinate of the ship centre of mass KG_{\max} or the minimum value of the metacentric height GM_{\min} (as a function of draught) ensuring compliance with the damage stability requirements ($A > R$),
- .2** data on structural measures to ensure the ship survival capability, instructions concerning the operation of cross-flooding arrangements and other emergency appliances,
- .3** recommendations, specific for the given ship, for proceedings under normal service conditions, as well as instructions for proceedings in the case of ship damage specifying the activities related to the ship survival.

5.2.4.4 *Damage Control Plan*, required in 1.4.2.2.2, shall be prepared in a form that would enable to keep it permanently exhibited for the guidance of the officer in charge of the ship. The scope of information, to be indicated on the plan and additionally provided in a booklet, available to the officers of the ship, is specified in IMO Circular *MSC.1/Circ.1245*. Additional information on the Plan reference to passenger ships constructed or subject to major conversion on 9 June 2017 or after that date, are included in IMO *MSC.1/Circ. 1570*.

The booklet shall contain information on the ship equalization and stability after damage, as well as on the position of damage waterlines with respect to openings through which progressive flooding may occur. The layout of the booklet shall be compatible with the *Damage Control Plan*.

5.2.5 Load Lines Position

5.2.5.1 An approved subdivision load line shall not be situated above the waterline corresponding to the minimum freeboard in salt water, assigned for a ship in accordance with the requirements specified in the *International Convention on Load Lines, 1966*.

5.2.5.2 In passenger ships, the subdivision load lines shall be marked in accordance with the requirements specified in *SOLAS II-1/18*.

5.2.6 Interpretations of and Departures from Requirements

5.2.6.1 Departures from the requirements of international conventions or codes, referred to therein, provided by the conventions or codes, interpretation of those requirements or setting forth detailed requirements concerning subdivision, may be the subject of consideration and decision by Polish Register of Shipping acting, in each particular case, on behalf of the Administration of the State whose flag the ship is entitled to fly.

5.3 Basic Requirements for Various Ship Types

5.3.1 Passenger Ships

5.3.1.1 Passenger ships engaged on international voyages, assigned an additional mark **PASSENGER SHIP**, in the symbol of class, as well as passenger ships engaged on domestic voyages which are assigned additional mark **PASSENGER SHIP** and additional mark **Class A**, affixed to the symbol of class shall fulfil the requirements concerning:

- .1 subdivision;
- .2 stability parameters of a damaged ship in the final stage of flooding and after equalization, where provided;
- .3 stability parameters of a damaged ship in intermediate stages of flooding;
- .4 the hull watertight integrity,

specified in *SOLAS Convention*, Chapter II-1, Part B, as amended.

5.3.1.2 The requirements, specified in 5.3.1.1, shall be applied in conjunction with *Resolution MSC.281(85): Explanatory Notes to the SOLAS Chapter II-1 Subdivision and Damage Stability Regulations* and *Stockholm Agreement* as well as explanatory notes, given in Annex 2.

5.3.1.3 Passenger ships engaged on domestic voyages assigned an additional mark **PASSENGER SHIP** and additional mark **Class B**, **Class C** or **Class D**, affixed to the symbol of class shall fulfil subdivision requirements specified in *Publication No. 76/P – Stability, Subdivision and Freeboard of Passenger Ships Engaged on Domestic Voyages*.

5.3.1.4 A ship complying with the requirements of sub-chapter 5.2 and the requirements specified in this sub-chapter 5.3.1 is assigned the additional mark **[P]** after the main symbol of class.

5.3.1.5 An existing passenger ship is assigned the additional mark **[1]** or **[2]** after the main symbol of class.

5.3.1.6 Ships having length as defined in regulation II-1/2.5 of *SOLAS*, 120 m or more or having three or more main vertical zones shall be designed so that the systems specified in regulation II-2/21.4 remain operational when the ship is subject to flooding* of any single watertight compartment.

* Refer to the *Interim Explanatory Notes* for assessment of passenger ship systems' capabilities after a fire or flooding casualty (MSC1/Circ.1369).

For the purpose of providing operational information to the Master for safe return to port after a flooding casualty, passenger ships constructed on or after 1 January 2014 shall have:

- onboard stability computer, or
- shore-based support

based on guidelines developed by IMO**.

5.3.1.7 The above ships are assigned an additional mark **SRP** in the symbol of class.

5.3.2 Cargo Ships

5.3.2.1 The requirements of the present sub-chapter apply to cargo ships, other than those specified in 5.3.3 to 5.3.11.

5.3.2.2 Cargo ships with the length $L_s \geq 80$ m shall fulfil the requirements concerning:

- .1 hull subdivision, taking into account probability that the ship will not capsize in damage condition and after flooding her compartment(s);
- .2 the hull watertight integrity;
- .3 probability of the ship survival,

specified in *SOLAS Convention*, Chapter II-1, Part B, as amended.

5.3.2.3 The requirements, specified in 5.3.2.2, shall be applied in conjunction with *Resolution MSC.281(85): Explanatory Notes to the SOLAS Chapter II-1 Subdivision and Damage Stability Regulations* and *Stockholm Agreement* as well as explanatory notes, given in Annex 2.

5.3.2.4 A ship complying with the requirements of sub-chapter 5.2 and the requirements specified in this sub-chapter 5.3.2 is assigned additional mark [s], affixed to the symbol of class.

5.3.3 Oil Tankers

5.3.3.1 The requirements of the present sub-chapter apply to ships assigned one of additional marks: **CRUDE OIL TANKER, PRODUCT CARRIER A, PRODUCT CARRIER B, OIL RECOVERY VESSEL**, affixed to the symbol of class.

5.3.3.2 Oil tankers shall fulfil the requirements concerning:

- .1 hull subdivision,
- .2 stability parameters of a damaged ship in the final stage of flooding a compartment/compartments and after equalization of the ship;
- .3 stability parameters of a damaged ship in intermediate stages of flooding a compartment/compartments (where investigation of intermediate stages of flooding is deemed justified by PRS), and
- .4 the hull watertight integrity, specified in regulation 28 of Annex I to *Convention MARPOL 73/78 with Protocol 1978 and Protocol 1997*, as further amended, as well as in IMO Unified Interpretations MEPC.1/Circ.867, and
- .5 Requirements specified International Convention on Load Lines 1966 as amended Chapter II, Reg. 27.

Guidance facilitating the proper calculations is provided in *Publication No. 94/P*.

5.3.3.3 A ship complying with the requirements of sub-chapter 5.2 and the requirements specified in this sub-chapter 5.3.3 is assigned the additional mark [T] after the main symbol of class.

5.3.3.4 Masters of oil tankers of 5000 tonnes deadweight and above shall be provided with ready access to shore-based software for calculations of stability and strength in damage condition.

** Refer to the *Guidelines on operational information for Master of passenger ships for safe return to port by own power or under tow* (MSC.1/Circ 1400).

5.3.4 Bulk Carriers

5.3.4.1 The requirements of the present Chapter apply to ships with the length $L \geq 150$ m of:

- single skin construction,
- double-side skin construction in which any part of longitudinal bulkhead is located within $B/5$ or 11.5 m (whichever is less), inboard from the ship side at right angle to the centre line at the assigned summer load waterline,

designed to carry solid bulk cargoes having a density of 1000 kg/m^3 and above, assigned an additional mark **BULK CARRIER**, affixed to the symbol of class.

5.3.4.2 Bulk carriers, referred to in 5.3.4.1, shall fulfil the requirements for damage stability, specified in *SOLAS XII/4*, as amended.

They shall also fulfil the requirements of regulations 5 to 14 of the above-mentioned *Convention*.

5.3.4.3 A ship complying with the requirements of sub-chapter 5.2 and the requirements specified in sub-chapter 5.3.2 is assigned an additional mark [s], affixed to the symbol of class.

5.3.5 Special Purpose Ships

5.3.5.1 The requirements of the present sub-chapter apply to ships assigned an additional mark **RESEARCH SHIP**, **TRAINING SHIP** or another mark indicating the ship type, as specified in paragraph 3.4.2.4 of *Part I – Classification Regulations*, affixed to the symbol of class.

5.3.5.2 Special purpose ships shall fulfil the requirements concerning:

- .1 subdivision;
- .2 stability parameters of a damaged ship in the final stage of flooding a compartment/compartments and after the ship equalization, where provided;
- .3 stability parameters of a damaged ship in intermediate stages of flooding a compartment/compartments;
- .4 the hull watertight integrity,

specified in *Code of Safety for Special Purpose Ships*, Chapter 2, introduced by IMO Resolution MSC.266(84) – see Annex 3.

5.3.5.3 A ship complying with the requirements of sub-chapter 5.2 and the requirements specified in this sub-chapter 5.3.5 is assigned the additional mark [SP] after the main symbol of class.

5.3.6 Fishing Vessels

5.3.6.1 The requirements of the present sub-chapter apply to fishing vessels assigned an additional mark **FISHING VESSEL** or **FISHING CUTTER**, affixed to the symbol of class.

5.3.6.2 Fishing vessels with the length $L \geq 100$ m, with the total number of persons carried ≥ 100 shall fulfil the requirements for:

- .1 the hull subdivision;
- .2 stability parameters of a damaged ship in the final stage of flooding any one compartment,

specified in regulation 14, Chapter III of Attachment 1 to the *1993 Torremolinos Protocol* (relating to *Torremolinos International Convention for the Safety of Fishing Vessels, 1977*) – see Annex 4.

5.3.6.3 To fulfil the requirements of the a.m. regulation 14, the provisions concerning the hull subdivision and damage stability calculations, contained in Recommendation 5 of Attachment 3 to the *1993 Torremolinos Protocol*, adopted by the 1993 International Conference on Safety of Fishing Vessels, shall be taken into account (see Annex 4).

5.3.6.4 A ship complying with the requirements of sub-chapter 5.2 and the requirements specified in this sub-chapter 5.3.6 is assigned an additional mark [1], affixed to the symbol of class.

5.3.7 Chemical Tankers

5.3.7.1 The requirements of the present sub-chapter apply to ships assigned an additional mark **CHEMICAL TANKER**, affixed to the symbol of class.

5.3.7.2 Chemical tankers shall fulfil the requirements concerning:

- .1 buoyancy after damage;
- .2 stability parameters of a damaged ship in the final stage of flooding a compartment/compartments and after the ship equalization, where provided;
- .3 stability parameters of a damaged ship in intermediate stages of flooding a compartment/compartments (if investigation of intermediate stages of flooding is deemed justified by PRS);
- .4 the hull watertight integrity,

specified in Chapter 2 of the *International Code for the Construction and Equipment of Ships Carrying Dangerous Chemicals in Bulk (IBC Code)*.

Guidance facilitating the proper calculations is provided in *Publication No. 94/P*.

5.3.7.3 A ship complying with the requirements of sub-chapter 5.2 and the requirements specified in this sub-chapter 5.3.7 is assigned the additional mark [**CH**] after the main symbol of class.

5.3.8 Gas Tankers

5.3.8.1 The requirements of the present sub-chapter apply to ships assigned an additional mark **LIQUEFIED GAS TANKER**, affixed to the symbol of class.

5.3.8.2 Gas tankers shall fulfil the requirements concerning:

- .1 buoyancy after damage;
- .2 stability parameters of a damaged ship in the final stage of flooding a compartment/compartments and after the ship equalization, where provided;
- .3 stability parameters of a damaged ship in intermediate stages of flooding a compartment/compartments (if investigation of intermediate stages of flooding is deemed justified by PRS);
- .4 the hull watertight integrity;
- .5 information on cargo loading and stability, as well as safe operation of the ship with respect to survival capability,

specified in Chapter 2 of the *International Code for the Construction and Equipment of Ships Carrying Liquefied Gases in Bulk (IGC Code)*.

Guidance facilitating the proper calculations is provided in *Publication No. 94/P*.

5.3.8.3 A ship complying with the requirements of sub-chapter 5.2 and the requirements of this sub-chapter 5.3.8 is assigned the additional mark [**G**] after the main symbol of class.

5.3.9 Ships of Type “A” and Ships of Type “B” with Reduced Freeboard

5.3.9.1 The requirements of the present Chapter apply to cargo ships, type “A” and type “B” with reduced freeboard.

5.3.9.2 Type “A” ships with the length $L > 150$ m shall be so subdivided as to fulfil the requirements for:

- .1 remaining afloat after damage and flooding of any one compartment;
- .2 stability parameters of a damaged ship,

specified in regulation 27 of the *International Convention on Load Lines, 1966* as amended.

5.3.9.3 Type “B” ships with the length $L > 100$ m, with reduced freeboard, shall fulfil the relevant requirements of regulation 27, referred to in 5.3.9.2.

5.3.9.4 A ship complying with the requirements of Chapter 5.2 and the requirements specified in this sub-chapter 5.3.9 is assigned an additional mark [**1**], affixed to the symbol of class.

5.3.10 Supply Vessels

5.3.10.1 The requirements of the present sub-chapter apply to supply vessels, assigned an additional mark **SUPPLY VESSEL**, affixed to the symbol of class.

5.3.10.2 Supply vessels with the length $24 \text{ m} \leq L < 100 \text{ m}$ shall fulfil the requirements concerning:

- .1 stability parameters of a damaged vessel in the final stage of flooding a compartment;
- .2 stability parameters of a damaged ship in intermediate stages of flooding (if investigation of intermediate stages of flooding is deemed justified by PRS);
- .3 the hull watertight integrity,

specified in Chapter 3 of *Guidelines for the Design and Construction of Offshore Supply Vessels*, introduced by IMO Resolution MSC.235(82) (see Annex 5).

5.3.10.3 The requirements for supply vessels with the length $L > 100 \text{ m}$ are specified separately by PRS in each particular case.

5.3.10.4 A ship complying with the requirements of sub-chapter 5.2 and the requirements specified in this sub-chapter 5.3.10 is assigned an additional mark [1] or [2], affixed to the symbol of class.

5.3.11 Tugs, Ice Breakers, Rescue Vessels and Dredgers

5.3.11.1 The requirements of the present sub-chapter apply to:

- .1 tugs with the length $L \geq 40 \text{ m}$, assigned an additional mark **TUG**, affixed to the symbol of class,
- .2 ice breakers with the length $L \geq 40 \text{ m}$,
- .3 rescue vessels, assigned additional mark **RESCUE VESSEL**, affixed to the symbol of class,
- .4 dredgers with the length $L \geq 60 \text{ m}$, assigned an additional mark **DREDGER**, affixed to the symbol of class.

5.3.11.2 The ship shall remain afloat after damage and the flooding of any one compartment, assuming the following extent of damage:

- .1 longitudinal extent equal to 3 m plus $0.03L$ or $0.1L$, or 11 m, whichever is the lesser;
- .2 transverse extent, measured inboard from the inner side of the shell plating at right angle to the centre plane, at the level of the deepest subdivision loadline, equal to $B/5$;
- .3 vertical extent, measured from the base plane upwards – without limits.

5.3.11.3 It is assumed that a ship fulfils the requirements for survival capability after damage if:

- .1 the initial metacentric height of the ship in the final stage of flooding a compartment is not less than 0.05 m before measures to increase the metacentric height have been taken;
- .2 the angle of heel in the final stage of unsymmetrical flooding prior to equalization is less than 20° , while after equalization – less than 12° ;
- .3 the damage stability righting levers curve after flooding satisfies the conditions:
 - the positive range of the curve, measured from the position of equilibrium, is not less than 15° ;
 - the maximum righting lever within the positive range of the curve is not less than 0.1 m;
 - the area under the curve within its positive range is not less than 0.015 m-rad;
- .4 the damage waterline before and during equalization of the ship is situated at least 0.3 m or $0.1 + (L_s - 10)/150$, whichever is lesser, below the openings in bulkheads, decks and the ship sides through which the flooding may take place.

5.3.11.4 The damage waterline in the final stage of flooding and after equalization, where provided, may be located above the bulkhead deck.

5.3.11.5 Where a damage of a lesser extent than those specified in 5.3.11.2, might result in non-compliance with the ship survival requirements, such extent of damage shall be taken into account in damage stability calculations.

5.3.11.6 Ships complying with the requirements of sub-chapter 5.2 and the requirements specified in this sub-chapter 5.3.11 is assigned an additional mark [1] or [2], affixed to the symbol of class.

5.4 Regional Requirements for Damage Stability of Ro-ro Passenger Ships

5.4.1 All ro-ro passenger ships operating to or from a port a Member State of the European Union on a regular service, regardless of their flag, when engaged of international voyages, shall fulfil the provisions of *Directive 2003/25/EC of the European Parliament and of the Council* of 14 April 2003, as amended by *Commission Directive 2005/12/EC* of 8 February 2005 on specific stability requirements for ro-ro passenger ships.

For ro-ro passenger ships undertaking international voyages between or to or from ports in Northwest Europe and the Baltic Sea, the *Agreement Concerning Specific Stability Requirements for Ro-Ro Passenger Ships Undertaking Regular Scheduled International Voyages between or to or from Designated Ports in NorthWest Europe and the Baltic Sea** (the Stockholm Agreement of 28 February 1996) applies.

5.4.2 To obtain confirmation of a ro-ro passenger ship compliance with the *Agreement* requirements, a supplement to the valid stability and subdivision booklet shall be submitted to PRS. The supplement shall contain the necessary information, calculations and data enabling to verify the calculations, as well as to ascertain that the ship fulfils the specific requirements for damage stability of ro-ro passenger ships.

5.4.3 Where compliance with the *Agreement* requirements results in imposing additional operational limits (deadweight, trims, the permissible locations of the vertical centre of mass, the sequence of using stores and ballasting, additional proceedings in the case of flooding certain compartments, etc.), a separate stability and *Subdivision Booklet* for the ship operation in the area covered by the specific requirements shall be prepared for the master.

5.4.4 Ro-ro passenger ship compliance with the requirements, referred to above, is recorded in Appendix to Certificate of Class.

5.5 Ships intended to operate in polar waters

5.5.1 Ships operating in areas of polar waters shall fulfill requirements specified in Chapter 4 of the *International Code for Ships Operating in Polar Waters (Polar Code)* (resolution MSC.385(94)).

* The requirements, specified in Annexes to the *Agreement*, shall be applied in conjunction with Guidance notes on these Annexes, contained in SLF 40/INF.14.

SUPPLEMENT RETROACTIVE REQUIREMENTS

1 General

1.1 The requirements of the present Supplement to *Part IV – Stability and Subdivision* apply to existing ships.

1.2 The scope of documentation, subject to PRS consideration and approval, is separately specified in each particular case.

2 Requirements on Subdivision

2.1 Passenger Ships

2.1.1 Passenger ships engaged on domestic voyages assigned an additional mark **PASSENGER SHIP** and an additional mark **Class A, Class B, Class C** or **Class D**, affixed to the symbol of class shall fulfil subdivision requirements specified in *Publication No. 76/P – Stability, Subdivision and Freeboard of Passenger Ships Engaged on Domestic Voyages* according to the schedule given in *Council Directive 98/18/EC of 17 March 1998, as amended by Commission Directive 2002/25/EC of 5 March, 2002*.

2.1.2 All ro-ro passenger ships operating to or from a port a Member State of the European Union on a regular service, regardless of their flag, when engaged on international voyages, shall fulfil the provisions of *Directive 2003/25/EC of the European Parliament and of the Council of 14 April 2003, as amended by Commission Directive 2005/12/EC of 8 February 2005 on specific stability requirements for ro-ro passenger ships by 1 October 2010*.

2.2 Cargo Ships

Cargo ships with the length $L_s \geq 100$ m, constructed on or after 1 February 1992, and cargo ships with the length $L_s \geq 80$ m, constructed on or after 1 July 1998, shall fulfil the requirements specified in sub-chapter 5.3.2 of *Part IV*.

2.3 Bulk Carriers

2.3.1 Single side skin bulk carriers with the length $L \geq 150$ m, designed to carry solid bulk cargoes having a density of 1780 kg/m^3 and above, contracted for construction prior to 1 July 1998, shall fulfil the requirements for damage stability specified in *SOLAS XII/4* on the dates given in *SOLAS XII/3*, as amended.*

2.3.2 Single side skin bulk carriers with the length $L \geq 150$ m, designed to carry solid bulk cargoes having a density of 1000 kg/m^3 and above, constructed on or after 1 July 1999, shall fulfil the requirements specified in sub-chapter 5.3.4 of *Part IV*.

* See also *Supplement to Part II – Hull*, sub-chapter 2.3.

HULL WATERTIGHT INTEGRITY

(Resolution MSC.267(85), Chapter 7)

1 Hatchways

1.1 Cargo and other hatchways in ships, to which the *International Convention on Load Lines, 1966* applies, shall comply with regulations 13, 14, 14-1, 15, 16 and 26(5) of the said *Convention*.

1.2 Hatchways in fishing vessels, to which the *1993 Torremolinos Protocol* applies, shall fulfil the requirements specified in regulations II/5 and II/6 of the said *Protocol*.

2 Machinery Space Openings

2.1 In ships, to which the *International Convention on Load Lines, 1966* applies, machinery space openings shall comply with regulation 17 of the said *Convention*.

2.2 In fishing vessels, to which the *1993 Torremolinos Protocol* applies, machinery space openings shall comply with regulation II/7 of the said *Protocol* *.

2.3 In supply vessels, access to the machinery space, if possible, shall be arranged within the forecastle. Any access to the machinery space from the exposed cargo deck shall be provided with two weathertight closures. Access to spaces below the exposed cargo deck shall be preferably from a position within or above the superstructure deck.

3 Doors

3.1 On both passenger and cargo ships, to which *SOLAS Convention* applies, doors shall fulfil the requirements of regulations II-1/13, II-1/13-1 and II-1/16 of the said *Convention*.

3.2 In ships, to which the *International Convention on Load Lines, 1966* applies, doors shall fulfil the requirements of regulation 12 of the said *Convention*.

3.3 In fishing vessels, to which the *1993 Torremolinos Protocol* applies, doors shall fulfil the requirements of regulation II/2 and II/4 of the said *Protocol*.

4 Cargo Ports and Other Similar Openings

4.1 In ships, to which the *International Convention on Load Lines, 1966* applies, cargo ports and other similar openings shall fulfil the requirements of regulation 21 of the said *Convention*.

4.2 On both passenger and cargo ships, to which *SOLAS Convention* applies, cargo ports and other similar openings shall fulfil the requirements of regulation II-1/15, 15-1 and 17 of the said *Convention*. Additionally, such openings in ro-ro passenger ships shall fulfil the requirements of regulation II-1/17-1 of the said *Convention*.

4.3 In fishing vessels, to which the *1993 Torremolinos Protocol* applies, openings through which water can enter the vessel shall fulfil the requirements of regulation II/3, para. 1. Fish flaps on stern trawlers shall fulfil the requirements of regulation II/3, paragraph 2 of the said *Protocol*.

5 Sidescuttles, Windows, Scuppers, Inlets and Discharges

5.1 In passenger ships, to which *SOLAS Convention* applies, openings in shell plating below the bulkhead deck shall fulfil the requirements of regulation II-1/15 of the said *Convention*.

Watertight integrity of the hull above the bulkhead deck shall fulfil the requirements of regulation II-1/17 of the said *Convention*.

* The requirements of regulation II/7 of the *1993 Torremolinos Protocol* are given in sub-chapter 14.5 of *Part III – Hull Equipment of the Rules for the Classification and Construction of Sea-going Ships*.

Additionally in ro-ro passenger ships, watertight integrity of the hull and superstructure shall fulfil the requirements of regulation II-1/17-1 of the said *Convention*.

5.2 In ships, to which the *International Convention on Load Lines, 1966* applies, scuppers, inlets and discharges shall fulfil the requirements of regulation 22 and sidescuttles shall fulfil the requirements of regulation 23 of the said *Convention*.

5.3 In fishing vessels, to which the *1993 Torremolinos Protocol* applies, sidescuttles and windows shall fulfil the requirements of regulation II/12 and inlets and discharges shall fulfil the requirements of regulation II/13 of the said *Protocol*.

5.4 In cargo ships, to which *SOLAS Convention* applies, external openings shall fulfil the requirements of regulation II-1/15-1 of the said *Convention*.

6 Other Deck Openings

6.1 Miscellaneous openings in freeboard and superstructure decks in ships, to which the *International Convention on Load Lines, 1966* applies, shall fulfil the requirements of regulation 18 of the said *Convention*.

7 Ventilators, Air Pipes and Sounding Devices

7.1 In ships, to which the *International Convention on Load Lines, 1966* applies, ventilators above the freeboard deck or enclosed superstructures deck shall fulfil the requirements of regulation 19, while air pipes shall fulfil the requirements of regulation 20 of the said *Convention*.

7.2 In fishing vessels, to which the *1993 Torremolinos Protocol* applies, ventilators shall fulfil the requirements of regulation II/9 of this Protocol, air pipes shall fulfil the requirements of regulation II/10 and sounding devices shall fulfil the requirements of regulation II/11 of this *Protocol*.

7.3 In supply vessels, air pipes and ventilators shall be fitted in protected positions in order to avoid damage by cargo during operations and to minimize the possibility of flooding. It is recommended that machinery space ventilating ducts should be led above the superstructure deck or above an equivalent level if no superstructure deck is fitted. Air pipes on the exposed cargo and forecastle decks shall be fitted with automatic closing devices.

EXPLANATORY NOTES TO SUBDIVISION AND DAMAGE STABILITY CALCULATIONS ACCORDING TO SOLAS II-1, PART B-1

The probabilistic concept, assumed for subdivision and damage stability assessment, differs appreciably from the deterministic approach. It is based on generalized results obtained by summation of partial components of the probability of ship damage occurrence and damage survival, made for a number of damage scenarios.

Although the probabilistic method, in the nature of things, offers a significant amount of freedom in establishing assumptions for calculations, one should adhere to the guidelines given in MSC.281(85) *Explanatory Notes to the SOLAS Chapter II-1 Subdivision and Damage Stability Regulations*.

Below are given additional notes and recommendations regarding establishing assumptions for subdivision index calculations:

1. The division of a ship into design damage zones shall be made based on typical, for the given ship, design solutions and it need not necessarily reflect the ship division into watertight compartments (Fig.1).

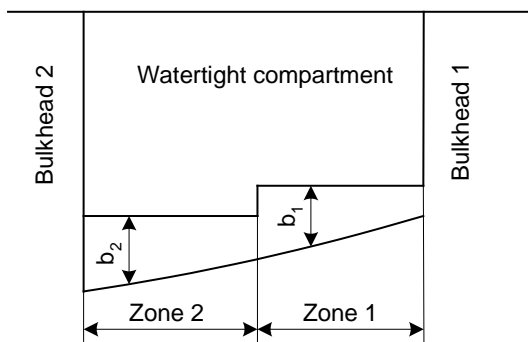

Fig. 1

2. If there are steps or recesses in transverse watertight bulkheads, it is acceptable to assume, for calculations, zones which are not adjacent (divisions with gaps between zones) so as to eliminate a substantial spreading of flooding over the other compartments in the case of a single compartment flooding. As a consequence, an insignificant loss of the portion of the probability component is observed, but the calculation model becomes more transparent (Fig.2).

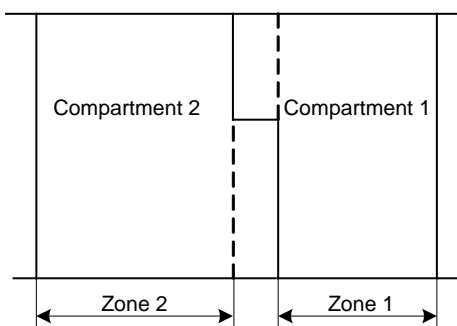

Fig. 2

3. The transverse division of a ship into flooding zones may be assumed for the design position of compartment boundary bulkheads if closing appliances of the bulkheads openings and shut off valves on the pipelines penetrating bulkheads are fitted directly on the bulkhead or the overall dimensions of those appliances/valves do not exceed half of the nearest frame spacing. Otherwise, the relevant zone boundary shall be corrected for the overall dimensions of the above mentioned appliances/valves (Fig 3).

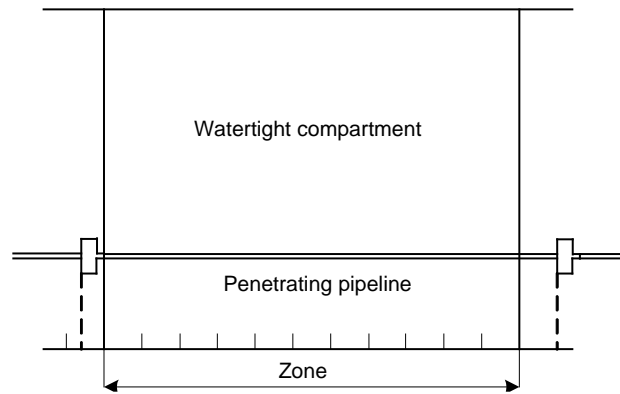

Fig. 3

4. When determining the horizontal division of a ship into watertight compartments, the design height of the compartment may be assumed if the overall dimensions of the drain wells and shut off valves do not exceed the height of the deck structural members. Otherwise, the relevant design height of the compartment shall be corrected (Fig. 4).

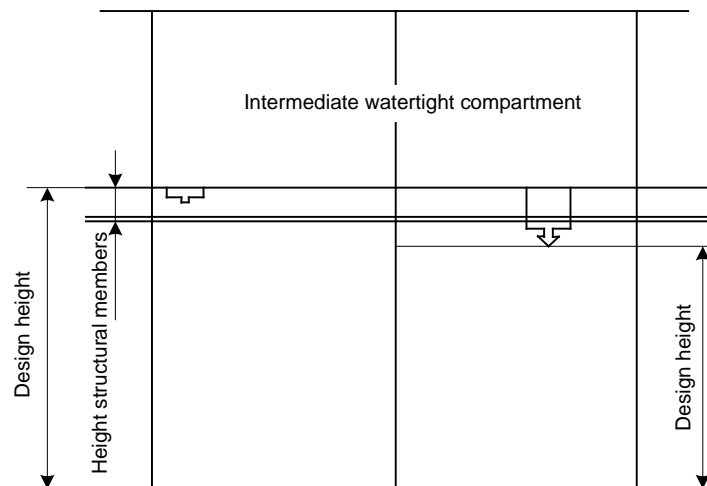

Fig. 4

5. The complexity degree of the ship division into zones shall be assumed based on the value of the required subdivision index R and the size of the zones. Calculations are usually performed for 2÷4 zones.
6. Watertight doors located above the bulkhead deck, but within damage waterlines, provided to prevent the spreading of flooding, may be taken into account in calculations if they fulfil the following conditions:
- .1 their strength is sufficient at the most unfavourable locations of damage waterlines, including intermediate stages of flooding;
 - .2 they are provided with an indicator, located on the navigating bridge, which shows by alarm if the doors are not fully closed;
 - .3 they are provided with a warning inscription: **“To be closed at sea”**.
7. PRS may give consent to minor departures from the assumed calculation model if, on the basis of the submitted data, the Society is satisfied that the safety of the ship will not be thereby impaired. The departures may concern the following:
- .1 small recesses in the bulkheads, the inner bottom and decks if located reasonably inboard of the ship side,
 - .2 small diameter pipelines passing through watertight bulkheads, not provided with shut off valves (e.g. CO₂ system pipelines),
 - .3 local differences between the Rule transverse extent of damage and that assumed in the case of damage above H_{max} .

**SUBDIVISION AND DAMAGE STABILITY
OF SPECIAL PURPOSE SHIPS**

(Resolution MSC.266(84); *Code of Safety for Special Purpose Ships*, Chapter 2)

CHAPTER 2 STABILITY AND SUBDIVISION

2.1 *

2.2 The subdivision and damage stability of special purpose ships should in general be in accordance with *SOLAS* chapter II-1 where the ship is considered a passenger ship, and special personnel are considered passengers, with an *R*-value calculated in accordance with *SOLAS* regulation II-1/6.2.3 as follows:

- .1** where the ship is certified to carry 240 persons or more, the *R*-value is assigned as *R*;
- .2** where the ship is certified to carry not more than 60 persons, the *R*-value is assigned as $0.8R$;
- .3** for more than 60 (but not more than 240) persons, the *R*-value should be determined by linear interpolation between the *R*-values given in .1 and .2 above.

2.3 For special purpose ships to which 2.2.1 applies, the requirements of *SOLAS* regulations II-1/8 and II-1/8-1 and of *SOLAS* chapter II-1, parts B-2, B-3 and B-4 should be applied as though the ship is a passenger ship and the special personnel are passengers. However, *SOLAS* regulations II-1/14 and II-1/18 are not applicable.

2.4 For special purpose ships to which 2.2.2 or 2.2.3 applies, except as provided in 2.5, the provisions of *SOLAS* chapter II-1, parts B-2, B-3 and B-4 should be applied as though the ship is a cargo ship and the special personnel are crew. However, *SOLAS* regulations II-1/8 and II-1/8-1 need not be applied and *SOLAS* regulations II-1/14 and II-1/18 are not applicable.

2.5 All special purpose ships should fulfil *SOLAS* regulations II-1/9, II-1/13, II-1/19, II-1/20, II-1/21 and II-1/35-1, as though the ship is a passenger ship.

* The stability criteria for an intact ship are given in Chapter 2 of *Part IV – Stability and Subdivision*.

ANNEX 4

SUBDIVISION AND DAMAGE STABILITY OF FISHING VESSELS*(1993 Torremolinos Protocol, Attachment 1, Chapter III, regulation 14)***Regulation 14*****Subdivision and damage stability***

Vessels of 100 m in length and over, where the total number of persons carried is 100 or more, shall be capable, to the satisfaction of the Administration, of remaining afloat with positive stability ($GM > 0$), after the flooding of any one compartment assumed damaged, having regard to the type of vessel, the intended service and area of operation.

**GUIDANCE ON SUBDIVISION AND DAMAGE STABILITY CALCULATIONS
(REGULATION III/14))***(1993 Torremolinos Protocol, Attachment 3, recommendation 5)***1. Conditions of Equilibrium**

- (a) The final waterline after damage to any one compartment should be either:
 - (i) to the line of openings at which progressive flooding to spaces below would occur and to the requirements of the Administration; or
 - (ii) to the after end of the top of the poop superstructure deck at the centreline, subject to paragraph (3)(a) below.
- (b) Unsymmetrical flooding shall be kept to a minimum consistent with efficient arrangements. Where it is necessary to correct large angles of heel, the means adopted shall, where practicable, be self-acting.

2. Damage Assumptions

The following assumed damage should apply:

- (a) The vertical extent of damage in all cases is assumed to be from the base line upwards without limit.
- (b) The transverse extent of damage is equal to $B/5$ m, measured inboard from the side of the vessel perpendicularly to the centreline at the level of the deepest operating waterline, where B (in metres) is as defined in regulation I/2(7).
- (c) If damage of a lesser extent than that specified in subparagraphs (a) and (b) above results in a more severe condition, such lesser extent should be assumed.
- (d) The flooding should be restricted to any single compartment between adjacent transverse watertight bulkheads. If there are steps or recesses in a transverse bulkhead of not more than 3.05 m in length located within the transverse extent of the assumed damage as defined in subparagraph (b) above, such transverse bulkheads may be considered intact and the adjacent compartments may be regarded as floodable singly. Where there exists a step or recess within the transverse extent of the assumed damage of more than 3.05 m in length in a transverse bulkhead, the two compartments adjacent to this bulkhead should be considered as flooded. The step formed at the junction of the afterpeak bulkhead and the afterpeak tank top should not be regarded as a step.
- (e) Where a main transverse bulkhead is situated within the transverse extent of assumed damage and is stepped in way of a double bottom tank or side tank by more than 3.05 m, the double bottom or side tanks adjacent to the stepped portion of the main transverse bulkhead should be considered as flooded simultaneously.
- (f) Main transverse watertight bulkheads should be spaced at least $1/3L^{2/3}$ m apart, where L (in metres) is as defined in regulation I/2(5). Where transverse bulkheads are spaced at a lesser distance, one or more of these bulkheads should be assumed as non-existent in order to achieve the minimum spacing between bulkheads.
- (g) If pipes, ducts or tunnels are situated within the assumed extent of damage penetration as defined in subparagraph (b) above, arrangements shall be made so that progressive flooding cannot thereby extend to compartments other than those assumed to be floodable in the calculation for each case of damage.

- (h) Where operating experience has shown that other values for subparagraphs (b) and (f) above are more appropriate, those values should be used.

3. Survival Assumptions

The vessel is considered to survive the conditions of damage specified in paragraph (2) above provided the vessel remains afloat in a condition of stable equilibrium and satisfies the following stability criteria:

- (a) The stability in the final condition of flooding may be regarded as sufficient if the righting lever curve has a minimum range of 20° beyond the position of equilibrium in association with a residual righting lever of at least 100 mm. The area under the righting lever curve within this range should be not less than 0.0175 m-rad. Consideration shall be given to the potential hazard presented by protected or unprotected openings which may become temporarily immersed within the range of residual stability. The unflooded volume of the poop superstructure around the machinery space casing, provided the machinery space casing is watertight at this level, may be taken into consideration in which case the damage waterline shall not be above the after end of the top of the poop superstructure deck at the centreline.
- (b) The angle of heel in the final condition of flooding should not exceed 20° .
- (c) The initial metacentric height of the damaged vessel in the final condition of flooding for the upright position shall be positive and not less than 50 mm.

4. Permeabilities

The permeabilities employed shall be those as calculated or estimated for the individual spaces in question.

5. Initial Condition of Loading

The subdivision and stability calculation should be performed in the worst operating condition in respect of the residual buoyancy and stability in the non-icing condition.

ANNEX 5

SUBDIVISION AND DAMAGE STABILITY OF SUPPLY VESSELS

(Guidelines for the Design and Construction of Supply Vessels;
Resolution MSC.235(82), Chapter 3)

3 SUBDIVISION AND DAMAGE STABILITY**3.1 General**

Taking into account, as initial conditions before flooding, the standard loading conditions required by 2.9 and 2.10* and the damage assumptions in 3.2, the vessel should fulfil the damage stability criteria as specified in 3.3.

3.2 Damage Assumptions

3.2.1 Damage should be assumed to occur anywhere in the vessel's length between transverse watertight bulkheads.

3.2.2 The assumed extent of damage should be as follows:

- for vessels with the length (L) not greater than 43 m: 10% of L ,
- for vessels with the length (L) greater than 43 m: 3 m plus 3% of L .

For vessels the keel of which is laid or which are at similar stage of construction** on or after 22 November 2012:

- for vessels with length (L) not greater than 43 m: 10% of L ,
- for vessels with length (L) greater than 43 m and less than 80 m: 3 m plus 3% of L ,
- for vessels with length (L) from 80 m to 100 m: $1/3 L^{2/3}$.

3.2.3 The assumed vertical extent of damage should be from the underside of the cargo deck, or the continuation thereof, for the full depth of the vessel.

3.2.4 Transverse extent of damage should be assumed as 760 mm, measured inboard from the side of the vessel perpendicularly to the centerline at the level of the summer load waterline.

For vessels the keel of which is laid or which is at a similar stage of construction on or after 22 November 2012:

- for vessels with length (L) less than 80 m: 760 mm,
- for vessels with length (L) from 80 m to 100 m: $B/20$, but not less than 760 mm (B – breadth of a vessel).

The transverse extent should be measured inboard from the side of the vessel perpendicularly to the centerline at the level of the summer load waterline.

3.2.5 A transverse watertight bulkhead extending from the vessel's side to a distance inboard of 760 mm or more at the level of the summer load line joining longitudinal watertight bulkheads may be considered as a transverse watertight bulkhead for the purpose of the damage calculations.

For vessels the keel of which is laid or which are at a similar stage of construction on or after 22 November 2012:

- for vessels with length (L) than 80 m, a transverse watertight bulkhead extending from the vessel's side to a distance inboard of 760 mm or more at the level of the summer load line joining longitudinal watertight bulkheads may be considered as a transverse watertight bulkhead for the purpose of the damage calculations,

* These loading conditions are specified in para. 3.9.3, *Part IV – Stability and Subdivision*.

** 'A similar stage of construction' means the stage at which:

- a) construction identifiable with a specific ship begins, and
- b) assembly of that ship commenced comprising at least 50 tonnes or one per cent of the estimated mass of all structural material, whichever is less.

- for vessels with length (L) from 80 m to 100 m, a transverse watertight bulkhead extending from the vessel's side to a distance inboard of $B/20$ or more (but not less than 760 mm) at the level of the summer load line joining longitudinal watertight bulkheads may be considered as a transverse watertight bulkhead for the purpose of the damage calculations.

3.2.6 If pipes, ducts or tunnels are situated within the assumed extent of damage, provision shall be made to ensure that progressive flooding cannot thereby extend to compartments other than those assumed to be floodable for each case of damage.

3.2.7 If damage of a lesser extent than that specified in 3.2.2 and/or 3.2.3 and/or 3.2.4 results in a more severe condition, such lesser extent should be assumed.

3.2.8 Where a transverse watertight bulkhead is located within the transverse extent of assumed damage and is stepped in way of a double bottom or side tank by more than 3.05 m, the double bottom or side tank adjacent to the stepped portion of the transverse watertight bulkhead should be considered as flooded simultaneously.

3.2.9 If the distance between adjacent transverse watertight bulkheads or the distance between the transverse planes passing through the nearest stepped portions of the bulkheads is less than the longitudinal extent of damage given in 3.2.2, only one of these bulkheads should be regarded as effective for the purpose of 3.2.1.

3.3 Damage stability criteria

3.3.1 The final waterline, taking into account sinkage, heel and trim, should be below the lower edge of any opening through which progressive flooding may take place. Such openings should include air pipes and those which are capable of being closed by means of weathertight doors or hatch covers and may exclude those openings closed by means of watertight manhole covers and flush scuttles, small watertight cargo tank hatch covers which maintain the high integrity of the deck, remotely operated watertight sliding doors and sidescuttles of the non-opening type.

3.3.2 In the final stage of flooding, the angle of heel due to unsymmetrical flooding should not exceed 15° . This angle may be increased up to 17° if no deck immersion occurs.

3.3.3 The stability in the final stage of flooding should be investigated and may be regarded as sufficient if the righting lever curve has, at least, a range of 20° beyond the position of equilibrium in association with a maximum residual righting lever of at least 100 mm within this range. Unprotected openings should not become immersed at an angle of heel within the prescribed minimum range of residual stability unless the space in question has been included as a floodable space in calculations for damage stability. Within this range, immersion of any of the openings referred to in 3.3.1 and any other openings capable of being closed weathertight may be authorized.

3.3.4 The Administration should be satisfied that the stability is sufficient during intermediate stages of flooding.

3.4 Assumptions for calculating damage stability

3.4.1 Compliance with 3.3 should be confirmed by calculations which take into consideration the design characteristics of the vessel, the arrangements, configuration and permeability of the damaged compartments and the distribution, specific gravities and the free surface effect of liquids.

3.4.2 The permeability of compartments assumed to be damaged should be as follows:

Spaces	Permeability
Appropriated to stores	60
Occupied by accommodation	95
Occupied by machinery	85
Void spaces	95
Intended for dry cargo	95

The permeability of tanks should be consistent with the amount of liquid carried, as shown in the loading conditions specified in 3.1. The permeability of empty tanks should be assumed to be not less than 95.

3.4.3 The free surface effect should be calculated at an angle of heel of 5° for each individual compartment, or the effect of free liquid in a tank should be calculated over the range of positive residual righting arm, by assessing the shift of liquids by moment of transference calculations.

3.4.4 Free surface for each type of consumable liquid should be assumed for at least one transverse pair of tanks or a single centreline tank. The tank or tanks to be taken into account should be those where the effect of free surface is the greatest.

3.4.5 Alternatively, the actual free surface effect may be used provided the methods of calculation are acceptable to the Administration.

3.5 Subdivision

3.5.1 The machinery spaces and other working and living spaces in the hull shall be separated by watertight bulkheads.

3.5.2 Means provided to maintain the watertight integrity of openings in watertight subdivisions shall fulfil the relevant provisions for cargo ships contained in chapter II-1 of the *SOLAS Convention*.

3.5.3 A collision bulkhead shall be fitted that fulfils relevant provisions for cargo ships of chapter II-1 of the *SOLAS Convention*.

3.5.4 An afterpeak bulkhead shall be fitted and made watertight up to the freeboard deck. The afterpeak bulkhead may, however, be stepped below the freeboard deck, provided the degree of safety of the vessel as regards subdivision is not thereby diminished.

INTERPRETATION TO DAMAGE STABILITY CALCULATIONS OF SHIPS CARRYING TIMBER DECK CARGOES

(According to *SOLAS II-1*, Regulation 5-1.1)

For ships specified in 3.5, the buoyancy of the timber deck cargo can be taken into account in the damage stability calculations, provided that the ships fulfil the requirements set forth in *IMO Code of Safe Practice for Ships Carrying Timber Deck Cargoes* and are assigned timber load waterline in accordance with regulations 41-45 of the *International Convention on Load Lines, 1966*.

1. Definitions

Deepest timber subdivision load line – the subdivision load line which corresponds to the timber summer draught to be assigned to the ship.

Respective partial load line – the light ship draught plus 60% of the difference between the light ship draught and the deepest timber subdivision load line.

2. Interpretation

- The stowage of timber deck cargoes shall fulfil the provisions of Chapter 3 of the above mentioned *Code*,
- The ship shall be provided with *Stability Booklet*, which takes into account timber deck cargo and which will enable the master, rapidly and simply, to obtain accurate guidance as to the stability of the ship under varying conditions of service as required in *SOLAS II-1/5-1*. This document shall include a curve of minimum operating metacentric height GM_{\min} as a function of draught, complying with the requirements of *SOLAS II-1/5-1.2.1*,
- The height and extent of the timber deck cargo shall fulfil the provisions of Chapter 3.2 of the above mentioned *Code*. The timber deck cargo shall be stowed to at least the standard height of one superstructure,
- Account may be taken of the buoyancy of the timber deck cargo, assuming that such cargo has a permeability of 25% of the volume occupied by the cargo, however, the buoyancy of only one standard superstructure height of timber deck cargo may be considered,
- Unless provided otherwise by the Administration, the *Stability Booklet* for ships with timber deck cargoes shall be supplemented by a second curve of limiting GM_{\min} (or KG_{\max}) covering the permissible draught range. The second curve shall be applicable when carrying timber deck cargo. The limiting GM shall be varied linearly between that for the deepest timber subdivision load line and the respective timber partial load line. Where timber freeboards are not assigned, the deepest and partial draughts shall be related to the summer load line. For any loading condition other than timber deck cargo, the limiting GM_{\min} (or KG_{\max}) with the draughts according to *SOLAS II-1/5-1.4* shall be applicable,
- For the purpose of the subdivision and damage stability calculations, the permeability of each space (or part of space) for both draughts shall be taken as 0.25.

When considering the vertical extent of damage, the upper deck may be regarded as a horizontal subdivision (in accordance with *SOLAS II-1/7-2.6*). Thus when calculating damage cases limited vertically to the upper deck with the corresponding ν factor, the timber deck cargo may be considered to remain buoyant with an assumed permeability of 0.25. For damage extending above the upper deck, the timber deck cargo buoyancy in way of the damage zone shall be ignored.

ANNEX 7

MINIMUM BOW HEIGHT

1 Determining Minimum Bow Height

1.1 Bow height, F_b , defined as the vertical distance measured at the fore perpendicular from the waterline corresponding to the summer freeboard and the designed trim to the upper surface of the exposed deck at side, shall not be less than:

$$F_b = [6075 \cdot (L/100) - 1875 \cdot (L/100)^2 + 200 \cdot (L/100)^3] \cdot [2.08 + 0.609 \cdot C_b - 1.603 \cdot C_{wf} - 0.0129] \cdot (L/T_1)$$

where:

F_b – calculated minimum bow height, [mm];

L – length of ship, as defined in Regulation 3 of the *International Convention on Load Lines*, [m];

B – breadth of ship, as defined in Regulation 3 of the *International Convention on Load Lines*, [m];

T_1 – draught at 85% of the least moulded depth, [m];

C_b – block coefficient, as defined in Regulation 3 of the *International Convention on Load Lines*, [m];

C_{wf} – block coefficient of the waterline bow part,

$$C_{wf} = A_{wf} / [(L/2) \cdot B]$$

A_{wf} – area of the waterline bow part at $L/2$,

For ships with the assigned timber waterline, the bow height shall be measured from the summer load line rather than the summer timber load waterline.

1.2 Where the bow height required in 1.1 is achieved by the sheer of deck, such a sheer shall extend for at least 15% of the length of ship abaft the forward perpendicular. If this is achieved by fitting a superstructure, then such a superstructure shall extend from the stem to the point located at least $0.07L$ abaft the forward perpendicular and shall be enclosed as required in Regulation 3(10) of the *International Convention on Load Lines*.

1.3 PRS may approve relaxations for ships who, due to exceptional operational circumstances, are incapable of complying with the requirements specified in 1.1 and 2.1 of this *Annex*.

1.4 In the bow height calculations, the forecastle sheer may be taken into account even where its length is less than $0.15L$ but not more than $0.07L$ provided that the forecastle height within $0.07L$ abaft the forward perpendicular is not less than a half of the required height of superstructure in accordance with Regulation 33 of the *International Convention on Load Lines*. If the forecastle height is less than a half of the required height of superstructure in accordance with Regulation 33 of the *International Convention on Load Lines*, then the correction for the bow height shall be determined as follows:

- If the freeboard deck sheer extends beyond $0.15L$ abaft, then the correction shall be determined in accordance with the parabolic sheer curve beginning at the point of $0.15L$ abaft the forward perpendicular at the height equal to the half of the moulded depth amidships and running through the intersection of the forecastle bulkhead with the deck and, further, to the point on the fore perpendicular located not higher than the forecastle deck surface. If the height marked in Fig. 1 as h_t is lower than that marked as h_b , then height h_t may be replaced by h_b within the bow height (Fig. 2).

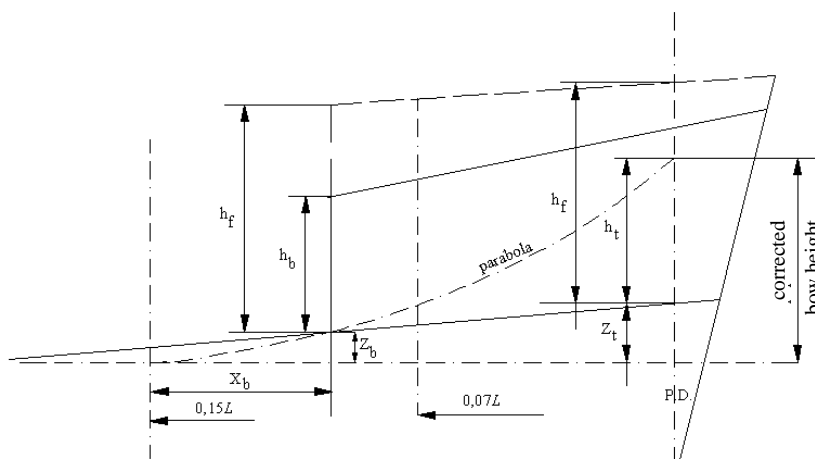

Fig. 1

$$h_f = z_b \frac{(0.15L)^2}{x_b} - z_t$$

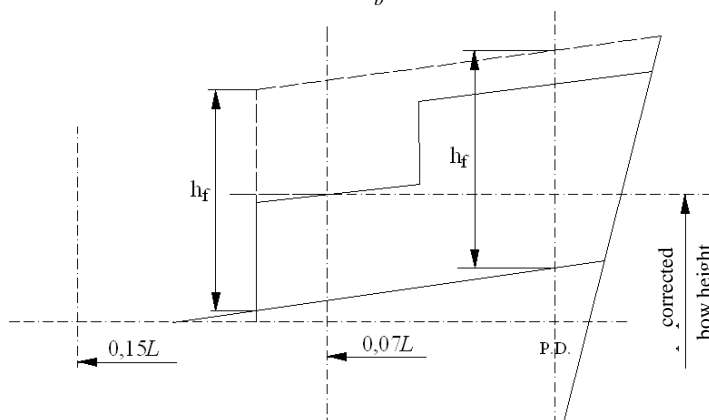

Fig. 2

- If the freeboard deck has sheer not reaching $0.15L$ abaft the forward perpendicular or has no sheer, then the correction shall be determined in accordance with the line led through the point located on the forecastle deck at side in the distance $0.07L$ abaft the forward perpendicular and parallel with the base plane to the intersection with the forward perpendicular (Fig. 2).

1.5 All ships with the assigned freeboard of type "B", other than oil tankers, chemical tankers and gas tankers shall have additional reserve buoyancy in the fore end of the ship. Within $0.15L$ abaft the forward perpendicular, the sum of areas of projections of the surfaces between the summer load water line and the deck line at side (A1 and A2 in Fig. 3) and the projection of surface (A3) of the enclosed superstructure (if provided) shall not be less than:

$$[0.15 \cdot F_{\min} + 4 \cdot (L/3 + 10)] \cdot L/1000, \quad [\text{m}^2],$$

where:

F_{\min} – determined as: $F_{\min} = (F_o \cdot f_1) + f_2$

F_o – tabular freeboard corrected in accordance with Regulation 27(9) or 27(10),

f_1 – correction for hull block coefficient in accordance with Regulation 30;

f_2 – correction for height in accordance with Regulation 31, [mm].

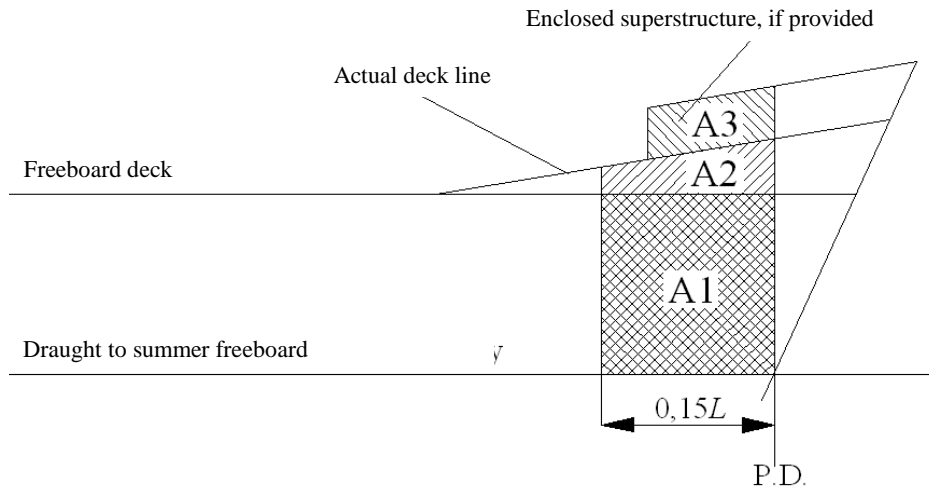

Fig. 3

List of amendments effective as of 1 January 2019

<i>Item</i>	<i>Title/Subject</i>	<i>Source</i>
1.2.1	Added: corrigendum to IS Code introduced by IMO	MSC 85/26/Add.1 Corr.3/Rev.1
2.1.1	Added: corrigendum to IS Code introduced by IMO	MSC 85/26/Add.1 Corr.3/Rev.1
3.14	New sub-chapter was added: Ships intended to operate in polar waters	Polar Code (res. MSC. 385(94))
5.5	New sub-chapter was added: Ships intended to operate in polar waters	Polar Code (res. MSC. 385(94))